



HEIDENHAIN



Operating Instructions

ND 287

English (en)
8/2010





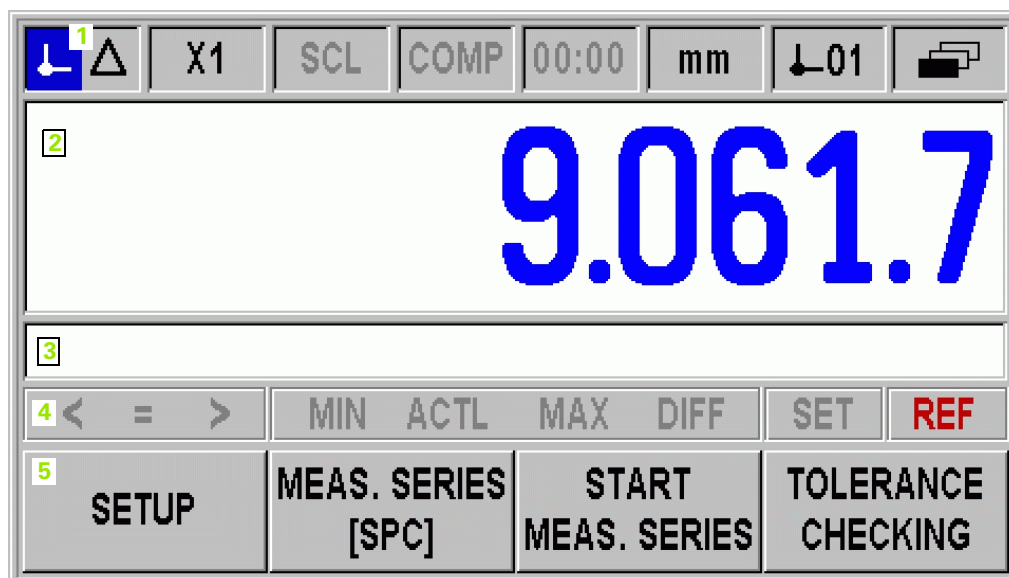





ND 287 Screen

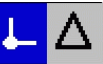

ND 287 Front Panel

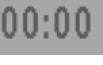

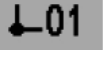
Controls and Displays

1	Status bar
	Current operating mode: Actual Value, Distance-To-Go.
	Current display mode for input X1, X2 or coupled axes X1:X2.
	SCL shown in black: Scaling factor is active.
	COMP shown in black: Error compensation or axis-error compensation is active for the currently displayed axis or coupled axes.
	Elapsed time of running stopwatch : If the stopwatch is stopped, the box appears dimmed.
	mm, inch, DEG, DMS or rad: Currently active unit of measure
	Currently active datum: The ND 287 allows you to work with two different datums.
	Indicates the soft-key page (soft-key row) you are currently on.

2 **Position display:** Current position value (length or angle), or other measured value

3 **Message line** for displaying information, errors or warnings.

4 **Status display:**

- <• / = / >: The first three symbols become effective when tolerance checking and sorting mode is activated.
- MIN, ACTL or MAX and DIFF: Minimum, current or maximum measured value of a series of measurements, or difference between minimum and maximum measured value.
- SET: If you enter a new value during datum setting, the SET symbol will start flashing.
- REF: The REF symbol is flashing until the reference mark evaluation for the displayed axis has been completed (if an incremental encoder is connected).

5 and 6 **Soft keys** and **soft-key buttons** for executing functions.

1,2,3,4... **Numeric input keys.**

ENTER Use the ENTER key to confirm your entry or to return to the previous screen.

C Use the C key to clear an entry, acknowledge an error message or return to the previous screen.



The NAVIGATION key moves through the soft-key pages (soft-key rows).

7 Use the UP or DOWN arrow key to move between fields within a form or menu items (parameters) within a menu.

ND 287 Rear Panel

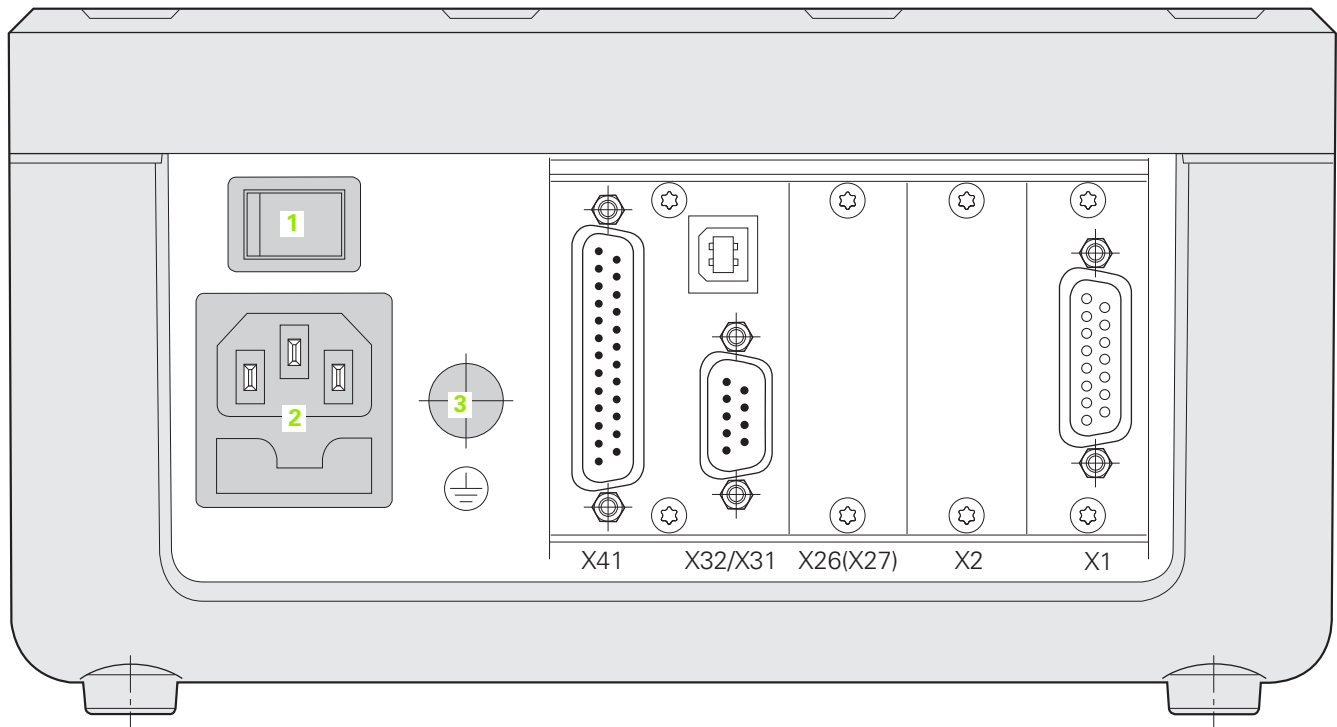

Connections

1	Power switch
2	Power connection with fuse
3	Ground (protective earthing)
X1	Encoder module for connecting a HEIDENHAIN encoder with 11 μApp , 1 Vpp or EnDat 2.1/2.2 interface Option: Analog module for connecting an analog sensor
X2	Optional: <ul style="list-style-type: none">■ Encoder module for connecting a HEIDENHAIN encoder with 11 μApp , 1 Vpp or EnDat 2.1/2.2 interface for a second axis or■ Analog module for connecting an analog sensor, primarily a temperature sensor for axis-error compensation
X26 (X27)	Option: Ethernet module (100baseT) for network connection via TCP/IP protocol
X32/X31	Two serial ports for data transfer: RS-232-C/V.24 (X31) and USB Type B (UART, X32)
X41	Switching inputs and outputs at D-sub connection

Introduction

Software version

The software version is shown on the power-up screen of the ND 287.



This manual describes the functions that are available in the ND 287 and the installation of the units.

Symbols within notes

Every note is marked with a symbol on the left indicating to the operator the type and/or potential severity of the note.



General information

e. g. on the behavior of the ND 287.



Refer to accompanying documents

e.g. when a special tool is required for a function.



Danger to the operator, workpiece or internal components

e.g. danger of collision



Electrical hazard

e. g. danger of electrical shock when opening a housing.



The ND 287 must be prepared by a qualified and authorized technician to perform this function.

Fonts

The chart below shows how the different variables (soft keys, hard keys, forms and form fields) are represented within the text of this manual:

- Soft keys – SETUP soft key
- Hard keys – ENTER hard key
- Menus and forms – UNITS OF MEASURE form
- Parameters and input fields – ANGULAR field
- Data in fields - ON, OFF

I Working with the ND 287 Position Display Unit 13

- I – 1 ND 287 Position Display Unit 14
- I – 2 Fundamentals of Positioning 16
 - Datums 16
 - Actual position, nominal position and distance-to-go 17
 - Absolute workpiece positions 18
 - Incremental workpiece positions 18
 - Incremental position encoders 19
 - Absolute position encoders 19
 - Reference marks 20
- I – 3 Basic Functions of the ND 287 21
 - Switching on the ND 287 21
 - Reference mark evaluation 22
 - Working without reference mark evaluation 22
 - Switching off the ND 287 22
 - Standard screen layout 23
 - Soft-key functions on the standard screen 25
 - Axis display mode 27
 - Data input 27
 - Integrated help system 28
 - Data input forms 29
 - Instruction box messages 29
 - Error messages 29
- I – 4 Job Setup 30
 - Operating modes 30
 - Datum setting 31
 - Setting the display value for one axis or for two axes in the X1 or X2 display mode 31
 - Setting the display value for two axes in display mode X1:X2 (applies to X1+X2, X1-X2, f(X1,X2)) 32
 - Calling the JOB SETUP menu 33
 - Unit of measure 34
 - Scaling factor 35
 - Value for datum point 36
 - Stopwatch 36
 - Console adjustment 37
 - Language 37
 - Switching signals 38
 - Measured value output 39
 - Function of external inputs 40
 - Compensation using a reference part 41

I – 5 Series of Measurements and Statistical Process Control	42
Functions	42
Switching between series of measurements and SPC mode	42
Calling the SERIES OF MEASUREMENTS menu	43
Analysis of series of measurements	43
Setting up a series of measurements	44
Defining the display for a series of measurements	46
Defining the record mode	47
Starting and stopping a series of measurements	48
Calling the SPC menu	49
SPC analysis	49
Setting up SPC	52
Samples	52
Tolerances	53
Control limits	54
Statistical distribution	55
Measured value recording	55
Deleting SPC statistics	56
Starting and stopping SPC	56
I – 6 Sorting and Tolerance Checking	58
Sorting function	58
Defining the sorting parameters	59
I – 7 Error messages	60
Overview	60

II Installation, Specifications 63

II – 1 Installation and Electrical Connection	64
Items supplied	64
Optional accessories	64
Mounting	65
Environmental conditions	65
Mounting location	65
ND 287 – Mounting and installation	65
Electromagnetic compatibility/ CE compliance	66
Electrical connection	67
Electrical requirements	67
Wiring the power connector	67
Grounding	67
Preventative maintenance or repair	68
Connecting the encoders	68
D-sub connection X1/X2 (15-pin, female) for the following input signals	68
Optional: Analog module with ± 10 -V interface at input X1 or X2 for connecting an analog sensor	69
II – 2 Installation Setup	70
INSTALLATION SETUP menu	70
Setting up the encoder	72
Incremental linear encoder	73
Incremental angle encoder	74
Absolute encoder	75
Analog sensor with ± 10 V interface, preferably a temperature sensor	76
Configuring the display	77
Linear encoder	77
Angle encoder	77
Analog sensor for compensation	77
Counter settings	78
Formula for coupled position	79
Error compensation	80
Linear error compensation (not for rotary encoders)	81
Non-linear error compensation	82
Setting up the serial port	86
Setting up the data interface	86
Diagnostics	88
Keypad test	88
Display test	88
Encoder test	89
Power supply	91
Switching inputs test	92
Switching outputs test	93

II – 3 Switching Inputs and Outputs	94
Switching inputs at D-sub connection X41	94
Input signals	95
Signal level of inputs	95
Ignoring the reference mark signals	95
Switching outputs at D-sub connection X41	96
Output signals	96
Signal level of outputs	96
Trigger limits	97
Sorting limits	98
Trigger signal for error	98
Zero crossover	98
II – 4 Encoder Parameters	99
Table values	99
HEIDENHAIN linear encoders	99
HEIDENHAIN angle encoders	100
II – 5 Data Interface	101
Data communication	101
Serial data transfer with the Import or Export function	102
Data transfer from the ND 287 to a printer	102
Data transfer from the ND 287 to a PC	102
Importing data into the ND 287 from a PC	103
Data format	103
Control characters	103
Software update (firmware update) installation	104
Wiring the connecting cable	105
USB Type B (UART), socket as per IEC 61076-3-108	106
External operation via RS-232-C/V. 24 or USB interface	107
Key commands	107
Description of key commands	108
Key is pressed (TXXXX commands)	109
Output of screen contents (AXXXX commands)	109
Execute function (FXXXX commands)	113
Execute special function (SXXXX commands)	113
II – 6 Measured Value Output	114
Alternatives for starting measured value output	114
Measured value output after a trigger signal	114
Propagation times	114
Duration of measured value transfer	114
Measured-value output via the serial data interface X31 or X32	115
Propagation times	115
Duration of measured value transfer	116
Example: Data sequence during measured-value output	116

II – 7 Input and Output of Parameter List and Error Compensation Table	117
Text file	117
Output format of the parameter list	118
First line	118
Second line	118
Subsequent lines for the individual parameters	118
Last line	118
Examples for parameter lists	119
ND 287 with rotary encoder connected to input X1	119
ND 287 with two rotary encoders connected to inputs X1 and X2 (optional)	122
Output format of the error compensation table	126
First line	126
Second line	126
Third line	126
Fourth line (only if second axis input is available, optional)	127
Fifth line	127
Sixth line	127
Seventh line	128
Subsequent lines for further compensation values	128
Last line	128
Examples of error compensation tables	129
ND 287 with linear encoder connected to input X1	129
ND 287 with two linear encoders connected to inputs X1 and X2 (optional)	131
ND 287 with rotary encoder connected to input X1	133
II – 8 Specifications	135
ND 287	135
II – 9 Dimensions	138
ND 287	138
II – 10 Accessories	139
ID numbers for accessories	139
Mounting the input assemblies	140
Mounting base for installation in 19-inch electrical cabinet	141

**Working with
the ND 287 Position
Display Unit**



I – 1 ND 287 Position Display Unit

The ND 287 position display unit from HEIDENHAIN is designed for measuring devices, adjustment and testing equipment, automated tasks, as well as infeed and positioning tasks with **up to two axes** that can be moved manually.

Linear/angular/rotary encoders, length gauges or analog sensors can be connected to the ND 287. The ND 287 features **two** slots for the connection of **modular input assemblies**:

- An **encoder module** for connecting an incremental photoelectrical HEIDENHAIN encoder with sinusoidal **11 μ App, 1 Vpp** signals or an absolute HEIDENHAIN encoder with bidirectional **EnDat 2.2/2.1** interface is a standard item supplied with the position display unit.
- **Optional** modules that can be easily adapted to the ND's requirements:
 - **Second encoder module** for connecting a HEIDENHAIN encoder with **11 μ App, 1 Vpp** or **EnDat 2.1/2.2 interface or**
 - **Analog module** for connecting an analog sensor with **± 10 V** interface, primarily a **temperature sensor for axis-error compensation**.

The following functions are available on the ND 287:

- Multilingual user guidance: Language can be selected by the user
- REF reference-mark evaluation for distance-coded or single reference marks
- Display of position value (length or angle), or of other measured values from analog sensors
- Distance-To-Go or Actual Value operating mode
- Two datums
- Scale factor
- Stopwatch
- Reset or Preset function, also through external signal
- Linear or non-linear error compensation for **axis-error compensation**
- Switching inputs and outputs



Fig. I.1 ND 287

- Series of measurements:
 - **Sorting** measured values and finding the **Minimum, Maximum, Sum, Difference** or a definable **coupled position value**.
Displaying the sorting results in order to intervene, if necessary.
 - Memory capacity for series of measurements: **Up to 10 000 measured values per axis**.
 - Analysis of series of measurements: **Arithmetical mean value, standard deviation, graphical representation** of all measured values with minimum, maximum and mean value of the series of measurements.
 - Measured-value acquisition by **external signal** or **selectable sampling interval**, or by pressing the ENTER key.
- **Statistical Process Control (SPC):**
 - Calculation of **arithmetical mean value, standard deviation** and **range**. Displaying **graphs** or histograms with **symmetrical or asymmetrical density function**.
 - **Process capability indices** c_p and c_{pk} , **quality control charts** for mean value, standard deviation and range.
 - Measured-value acquisition by **external signal** or by pressing the ENTER key.
 - FIFO memory capacity: **Up to 1000 measured values**.
- There are two serial ports for transmitting measured values, compensation values or configuration parameters to a PC or printer: The data can be transferred via the **RS 232-C/V.24** or the **USB Type B (UART)** interface. It is also possible to download software via the serial interface.
- **Diagnostic functions** for testing the encoder, the keyboard, the screen, the supply voltage and the switching inputs/outputs.
- On the ND 287, **one measured value can be displayed in large characters on the screen** at any one time. If two encoders are connected to the ND, you can switch the display from the position value supplied by the first encoder to the position value supplied by the second encoder, or to a defined coupled position value.
- The **integrated help system** provides information and assistance in any situation.



I – 2 Fundamentals of Positioning

Datums

The workpiece drawing identifies a certain point on the workpiece (usually a corner) as the **absolute datum** and perhaps one or more other points as relative datums.

The datum setting procedure establishes these points as the origin of the absolute or relative coordinate systems. The workpiece, which is aligned with the machine axes, is moved to a certain position relative to the length gauge and the display is set either to zero or to another appropriate value.

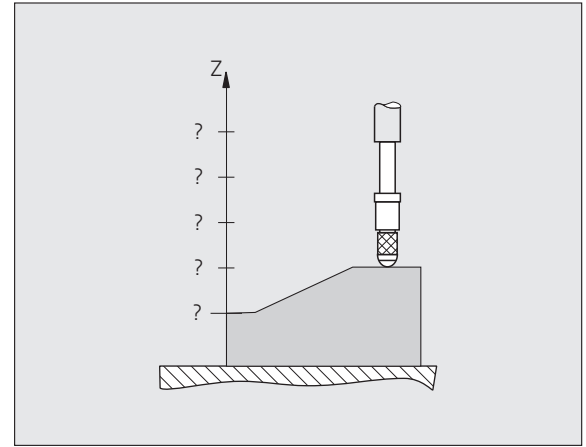

Fig. I.2 Length gauge without datum setting: Unknown assignment of measured values to positions

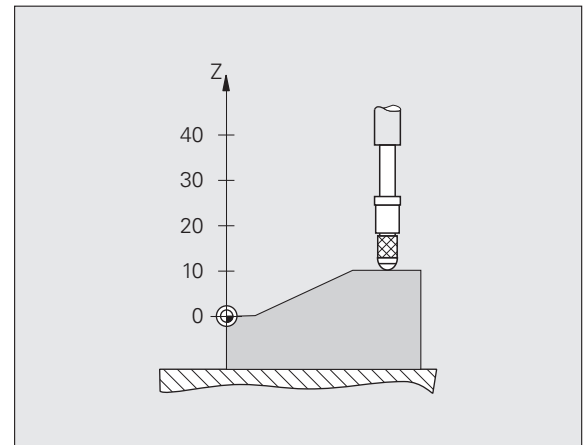

Fig. I.3 Length gauge with datum setting: Known assignment of measured values to positions

Actual position, nominal position and distance-to-go

The position of the length gauge at any given moment is called the **actual position**, while the position that the length gauge is to move to is called the **nominal position**. The distance from the nominal position to the actual position is called the **distance-to-go** (see Fig. I.4).

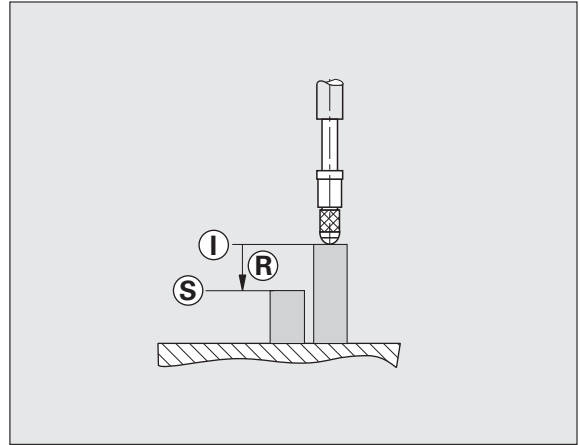

Fig. I.4 Nominal position **S**, actual position **I** and distance-to-go **R**

Absolute workpiece positions

Each position on the workpiece is uniquely identified by its absolute coordinates (see Fig. I.5).

Example: Absolute coordinates of position **1**: $Z = 20$ mm

If you are drilling or milling a workpiece according to a workpiece drawing with **absolute coordinates**, you are moving the tool or length gauge to the value of the coordinates.

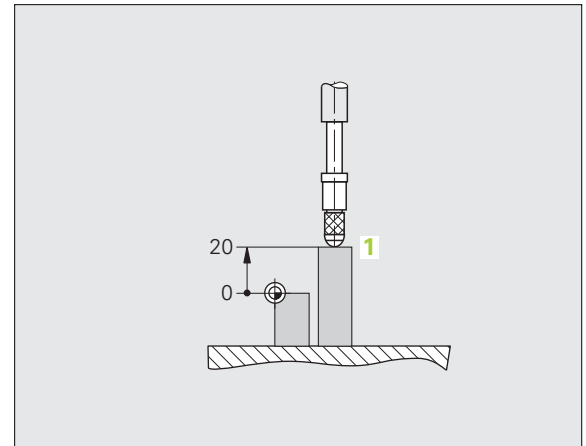

Fig. I.5 Position **1**: definition through absolute coordinates

Incremental workpiece positions

A position can also be referenced to the preceding nominal position. For this, the relative datum must be set to the preceding nominal position. Such coordinates are referred to as **incremental coordinates** (increment = increase). They are also called incremental or chain dimensions (since the positions are defined as a chain of dimensions). Incremental coordinates are identified by a preceding **I**.

Example: Incremental coordinate of position **3** referenced to position **2** see Fig. I.6.

Absolute coordinate of position **2**: $Z = 10$ mm

Incremental coordinates of position **3**: $I_Z = 10$ mm

If you are drilling or milling a workpiece according to a workpiece drawing with **incremental coordinates**, you are moving the tool or length gauge **by** the value of the coordinates.

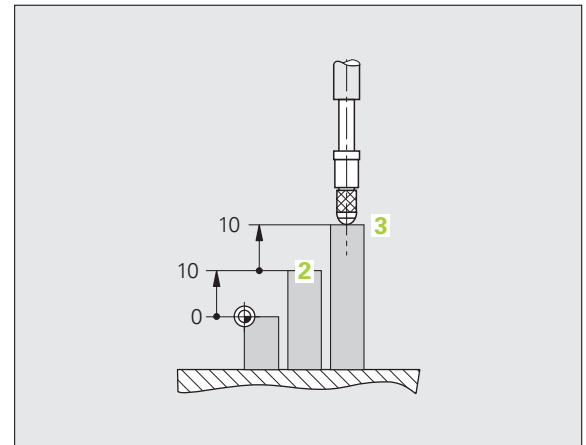

Fig. I.6 Position **3**: definition through incremental coordinates

Incremental position encoders

Incremental linear and rotary encoders from HEIDENHAIN convert the movements of, for example, a length gauge into electrical signals. A position display unit, such as the ND 287, constantly evaluates these signals and calculates the actual positions of the length gauge, which it displays as a numerical value on the screen.

If there is a power interruption, the calculated position will no longer correspond to the actual position of the length gauge. When power is restored, you can re-establish this relationship with the aid of the reference marks on the position encoders and the ND 287's reference mark evaluation feature.

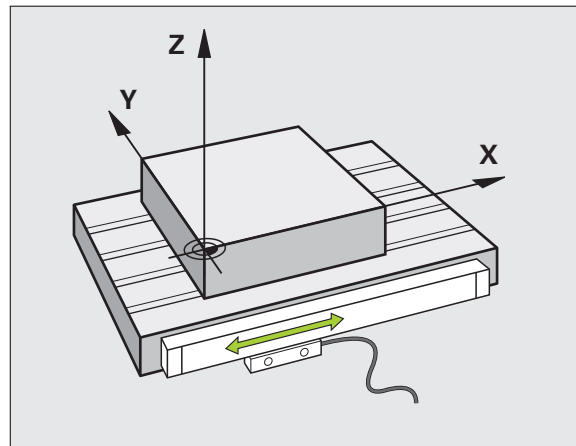

Fig. I.7 Linear position encoder, here for the X axis

Absolute position encoders

Absolute linear and rotary encoders from HEIDENHAIN transmit the absolute position value to the position display unit immediately after switch-on. This way the assignment of the actual position to the position of, for example, a length gauge is re-established directly after switch-on.

The encoder reads the absolute position information directly from the scale graduation (see Fig. I.8), and transmits it serially to the position display unit via the bidirectional EnDat 2.1/2.2 interface.

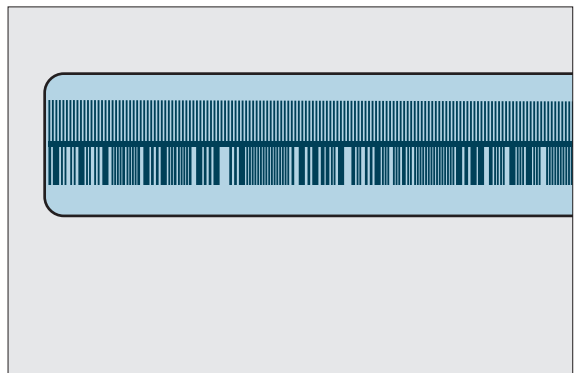

Fig. I.8 Scale grating for absolute position encoders

Reference marks

Encoders normally contain one or more reference marks (see Fig. I.9) which the ND 287's reference mark evaluation feature uses to re-establish datum positions after a power interruption. There are two main options available for reference marks: fixed and distance-coded.

Encoders with **distance-coded reference marks** have marks separated by a specific encryption pattern that allows the ND 287 to use any two pair of marks along the length of the encoder to re-establish the prior datums. This configuration means that the operator only has to travel a very short distance, anywhere along the encoder, to re-establish the datums when the ND 287 is turned back on.

Encoders with **fixed reference marks** have one or more marks on fixed intervals. To re-establish the datums correctly, it is necessary to use the same exact reference mark, during the reference mark evaluation routine, that was used when the datum was first established.



Danger to workpiece!

The established datums cannot be restored from one power cycle to the next if the reference marks were not crossed before the datums were set.

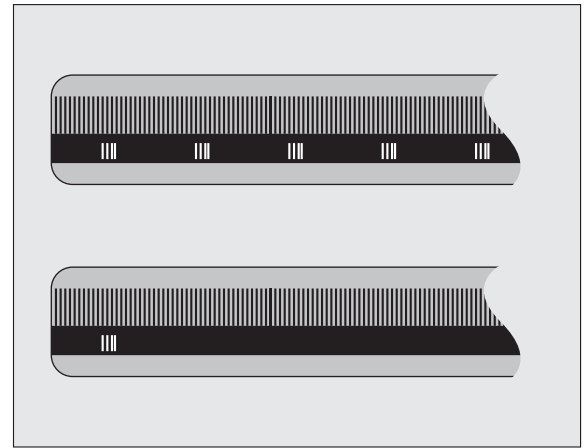

Fig. I.9 Linear scales – with distance-coded reference marks (upper illustration) and one reference mark (lower illustration)



I – 3 Basic Functions of the ND 287

Switching on the ND 287



Switch on the ND 287. The power switch is located on the back of the ND. After switching the ND 287 on, or after a power failure, the power-up screen will appear (see Fig. I.10). The green LED on the front panel lights up. The power-up screen shows the position display unit model as well as the ID and version number of the currently installed software.

Press the LANGUAGE soft key if you want to change the conversational language (see Fig. I.11). Press ENTER to confirm your selection.

Press the HELP soft key to call the integrated help system.

Press any key to call the standard screen.

Your ND 287 is now ready for operation in the Actual Value operating mode. If an incremental encoder is connected to the ND, the REF symbol is flashing. At this point the reference mark evaluation should be completed (see "Reference mark evaluation" on page 22).

If an absolute encoder is connected to the ND, the encoder automatically transmits the absolute position value to the position display unit.



- If necessary, you can change the language later, see "Language" on page 37.
- To update your software version (firmware version), see "Software update (firmware update) installation" on page 104.
- The idle time after which the ND activates the screen saver can be defined (factory default setting: 120 min, see "Console adjustment" on page 37). The red LED on the front panel lights up. To reactivate the screen, press any key or move the encoder.
- You can deactivate the power-up screen in order to display the standard screen immediately after power up (see "Counter settings" on page 78).

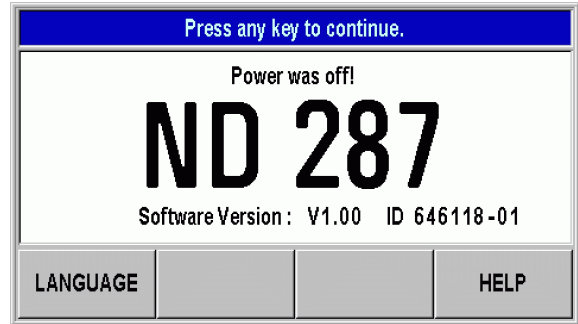

Fig. I.10 Power-up screen



Fig. I.11 Selecting the language



Reference mark evaluation

The ND 287's **REF** reference mark evaluation feature automatically re-establishes the relationship between axis-slide or length gauge positions and display values that you last defined by setting the datum.

Reference mark evaluation if an incremental encoder is connected (see Fig. I.12):

- ▶ If the REF symbol is flashing, cross over the reference marks.
- ▶ The REF mark evaluation feature determines the correct display value and the REF symbol stops flashing.

Working without reference mark evaluation

- ▶ Press the NO REF soft key to exit the reference mark evaluation routine and continue.
- ▶ In order to activate the reference mark evaluation feature at a later time, you can apply an external signal to **pin 25** at connection X41 (see "Setting up the encoder" on page 72), or you can switch the ND 287 off and then back on.



Danger to workpiece!

If an encoder is set up without reference marks, or if the reference marks have **not** been crossed over, then the REF indicator will appear dimmed, and datums set from any axis will be lost once power is turned off. This means that it is not possible to re-establish the relationship between axis slide positions and display values after a power interruption (switch-off).

Switching off the ND 287



Switch the ND 287 off. The measured values of a series of measurements will not be retained on a power cycle. The parameter settings, the error compensation tables or measured values that have been saved during statistical process control will stay in memory.

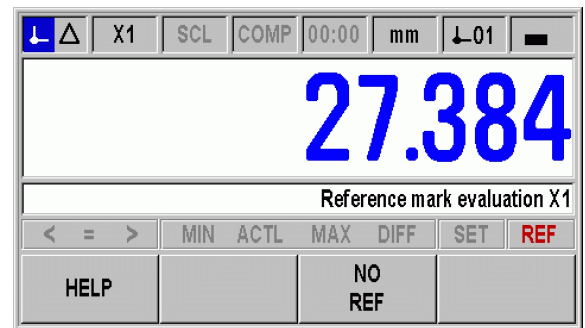



Fig. I.12 Screen for establishing reference marks



Standard screen layout

In addition to displaying position information, the ND 287 standard screen also displays information on settings and operating modes at any time (see Fig. I.13). The standard screen is divided into the following areas:

1 Status bar

- Current operating mode:  Actual Value,  Distance-To-Go.
- X1, X2 or X1:X2: Current display mode of axis or coupled axes.
- SCL shown in black: Scale factor is active.
- COMP shown in black: The error compensation or axis-error compensation is active for the currently displayed axis or coupled axes.
- Elapsed time of running **stopwatch**: If the stopwatch is stopped, the box appears dimmed.
- MM, INCH, DEG, DMS or RAD: Currently active unit of measure.
- Currently active datum: The ND 287 allows you to work with two different datums.
- Indicates the soft-key page (soft-key row) you are currently on.

2 Position display

- Length display:
Current axis value with algebraic sign.
- Angle display:
Current angle value with algebraic sign and unit of measure for display values in degrees, minutes or seconds.

3 Message line

- The message line provides information on the required data input or procedures, which is intended to support you in using the position display unit.
- If errors or warnings occur, they show up in red letters in the message line. Acknowledge the message with the C key.
- In the message line the ND 287 displays a measured-value counter in the series of measurements mode, and a sample counter in the SPC mode.
- If you have activated axis-error compensation with a temperature sensor, the ND shows the measured value of the temperature sensor at the left edge of the message line.
- If a multiturn rotary encoder is connected, the ND shows the number of revolutions at the right edge of the message line.

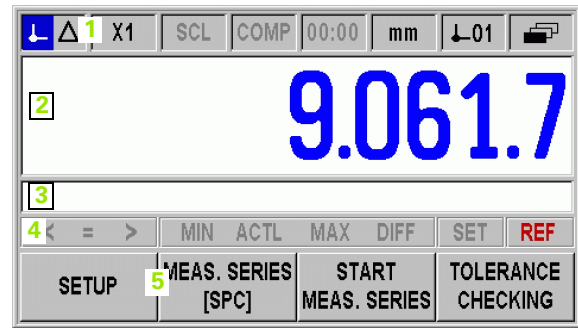

Fig. I.13 Standard screen



4 Status display

- < / = / >: The first three symbols become effective as soon as you activate the tolerance checking and sorting mode as well as during Statistical Process Control (SPC). The symbols are shown in red if the current value is less than the lower sorting limit or greater than the upper sorting limit. Green indicates that the value is within the two sorting limits.
- MIN, ACTL or MAX and DIFF: The symbols are only active, while a series of measurements is running. They indicate the display mode you have selected.
- Set: If you enter a new value during datum setting, the SET symbol will start flashing.
- REF: The REF symbol is flashing in red until the reference mark evaluation for the displayed axis has been completed (if an incremental encoder is connected).

5 Soft keys



The NAVIGATION key (shown at left) allows you to move through the three pages of selectable soft-key functions. Press the corresponding soft key directly below each soft key label to execute the soft-key function. The soft-key assignment varies depending on the ND's operating mode.



Soft-key functions on the standard screen



There are three pages (rows) of soft-key functions. Use the NAVIGATION key (shown at left) to move through the pages. The page indicator in the status bar shows the number of pages. The darkened page indicates the page you are currently on. This manual provides more information about each soft key on the pages indicated in the table below.



Fig. I.14 Page indicator

Soft key page 1:

Soft key	Function	Page
SETUP	Opens the JOB SETUP menu and provides access to the INSTALLATION SETUP soft key.	Page 30
MEAS. SERIES	Opens the SERIES OF MEASUREMENTS menu.	Page 42
START MEAS. SERIES	Starts a series of measurements.	Page 48
SPC	Opens the SPC menu.	Page 49
START SPC	Starts the SPC function.	Page 56
SORTING	Opens the SORTING AND TOLERANCE CHECKING menu.	Page 58

Soft key page 2:

Soft key	Function	Page
HELP	Calls the integrated help system.	Page 28
PRINT	Transmits the current measured value to a connected PC or printer via the serial interface.	Page 114
Distance-to-go On	Switches the display between operating modes Actual Value/ Distance-To-Go.	Page 30
MM inch	Switches the position display (length or angle) to the displayed unit of measure. The selected unit of measure is shown in the status bar.	Page 34
DEG		
DMS rad		



Soft key page 3:

Soft key	Function	Page
X1 [X2]	<ul style="list-style-type: none"> ■ This function is only available if the ND is configured for two axes: Switches the display mode in the status bar (X1, X2, X1:X2) and the display value. ■ The upper axis designation indicates the displayed axis, here X1. The lower axis designation in brackets (here, X2) appears in the respective field if you press the soft key again. Press the soft key repeatedly for the following display values: X1, X2, X1+X2, X1-X2 and formula f(X1, X2). 	Page 27, Page 78
DATUM	Switches the datum (see datum display in the status bar).	Page 31, Page 36,
PRESET	<ul style="list-style-type: none"> ■ Sets the axis value to the preset value for the datum. ■ If a coupled position X1:X2 is active, the ND sets X1 to the preset value for the datum and resets X2 to zero.. 	Page 31
RESET	<ul style="list-style-type: none"> ■ Actual Value mode: Resets the selected datum of the displayed axis to zero. If a coupled position is active, the ND resets the selected datum for both axes to zero. ■ Distance-To-Go mode: Resets the distance-to-go for the displayed axis to zero. If a coupled position is active, the ND resets the distance-to-go for both axes to zero. 	Page 31
MEASURE REF. PART	Display the measured values of a reference part: If temperature compensation using a reference part is activated, the ND 287 displays the current measured temperature value on the left side of the message line, and the entered nominal dimension of the reference part on the right side.	Page 41



Axis display mode

Press the X1-X2 [f(X1,X2)] soft key to select the desired display mode and the corresponding display value (see "Soft-key functions on the standard screen" on page 25):

Status Bar	Function
X1	<ul style="list-style-type: none"> ■ Display mode of axis X1 or input X1 ■ If an analog sensor is connected to input X2 and the ENCODER TYPE field under Encoder Setup, Input X2 is set to COMPENSATION, (see "Setting up the encoder" on page 72) the ND 287 behaves in the same way as a single-axis display unit (only X1).
X2	Display mode of axis X2 or input X2
X1:X2	Display mode for both axes: Display for X1+X2, X1-X2 or f(X1,X2).

 If you want to enter a formula for (X1,X2), select the formula editor, see "Counter settings" on page 78.

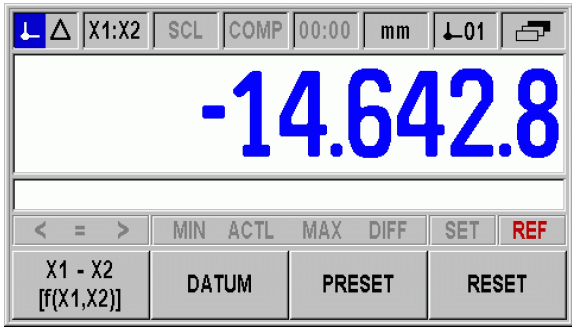

Fig. I.15 Standard screen with soft-key page 3

Data input

- Use the keypad to enter numeric values within each field.
- The ENTER key will confirm the entry within a field and return to the previous screen.
- Press the C key to clear entries, acknowledge error messages or return to the previous screen.
- **Soft-key labels 1** show the various operating and parameter-setting functions. These functions are selected by pressing the corresponding soft key directly below each soft key label. The soft-key functions are usually arranged in up to three soft-key pages (see below).
- The NAVIGATION key **2** moves through the pages of available soft-key functions. The current page will be highlighted in the status bar at the top of the screen.
- Use the UP or DOWN arrow key **3** to move between fields within a form or menu items (parameters) of a menu. The orientation of the cursor is such that it will return to the top once it has reached the bottom of the menu.



Fig. I.16 Data input



Integrated help system

The integrated help system provides appropriate information and assistance in any situation (see Fig. I.17).

To **call** the integrated help system:

- ▶ Press the HELP soft key.
- ▶ Information relevant to the current operation will be displayed.
- ▶ Use the UP or DOWN arrow keys or the PAGE UP or DOWN soft keys if the explanation is spread over more than one screen page.

To view information on another topic:

- ▶ Press the LIST OF TOPICS soft key to view the index of the help topics.
- ▶ Press the PART 1/[PART 2] soft key to call the extended help, which is available in exceptional cases.
- ▶ Press the UP or DOWN arrow key or the PAGE UP or PAGE DOWN soft key to scroll through the index.
- ▶ Press the VIEW TOPIC soft key or the ENTER key to select the item you need.

To leave the **integrated help system**:

- ▶ Press the C key. The ND will return to the screen from which you called the help system.

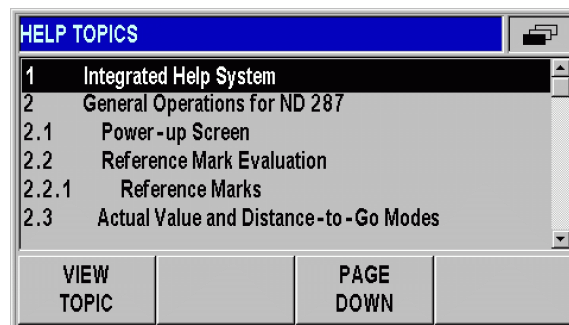

Fig. I.17 Integrated help system



Data input forms

Information required for various operational functions and setup parameters is entered through a data input form. These forms will appear after selecting features that require any additional information. Each form provides specific fields for entering the required information.

To confirm the changes:

- ▶ Press the ENTER key.

To ignore the changes and return to the previous screen:

- ▶ Press the C key.

Instruction box messages

Whenever a menu or form is open, an instruction box will also open immediately to the right of it (see Fig. I.18). This message box will provide information to the operator on what the chosen function does and present instructions on the available options.

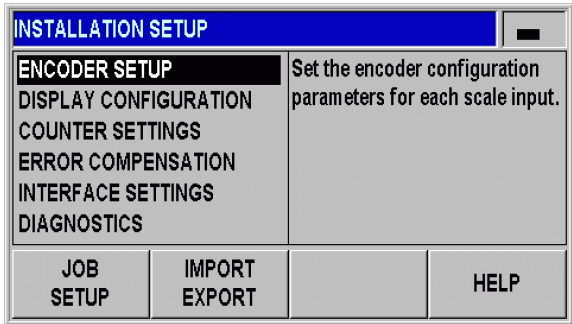



Fig. I.18 Example of instruction box messages

Error messages

If an error occurs while you are working with the ND, the message will appear on the display and provide an explanation of what caused the error.

To **acknowledge** the error message:

- ▶ Press the C key.

 If a new error occurs before the last error has been acknowledged, the last error that has occurred will be displayed. After the last error has been acknowledged, the previous error will be displayed again. The ND always stores the last error of each error category for acknowledgment (see "Error messages" on page 60).



I – 4 Job Setup

Operating modes

The ND 287 has two operating modes: **Actual Value** and **Distance-To-Go**.



Status Bar	Function
	Shows current actual position
	Displays current distance from the nominal position



Fig. I.19 Actual Value symbol (highlighted) in the status display

In the **Actual Value** operating mode, the ND 287 always displays the current actual position of the length gauge, relative to the active datum. In this mode, all moves are done by traveling until the display matches the nominal position that is required.

The **Distance-To-Go** feature enables you to approach nominal positions simply by traversing to display value zero. Proceed as follows:

- ▶ Press the DELTA MODE ON soft key to switch the operating mode (see "Soft-key functions on the standard screen" on page 25): The display value is zero.
- ▶ Use the numeric keys to enter the nominal position you want to move to and confirm with the ENTER key: The distance-to-go is displayed.
- ▶ Traverse the axis until the display value is zero.
- ▶ If required, enter the next nominal position and confirm with the ENTER key: Traverse the axis until the display value is zero.
- ▶ To leave the Distance-To-Go operating mode: Press the DELTA MODE OFF soft key.



Algebraic sign of distance-to-go:

- The distance-to-go has a positive sign if the axis direction from the actual towards the nominal position is negative.
- The distance-to-go has a negative sign if the axis direction from the actual towards the nominal position is positive.



In the **Distance-To-Go** operating mode, the switching outputs **A1** (pin 15) and **A2** (pin 16) have a **different function** (see "Switching outputs at D-sub connection X41" on page 96).



Datum setting

The datum setting procedure assigns the matching display value to a known position. With the ND 287 position display unit, you can set two separate datum points.

During operation, you can reset the display value of the axis to zero, or preset it to a defined or new value.



With RESET, you set the current datum to zero at the current position for that axis:

- If the **Actual Value mode** is active, the display value is zero.
- If the **Distance-To-Go mode** is active, the distance remaining to the position of the new datum is displayed.

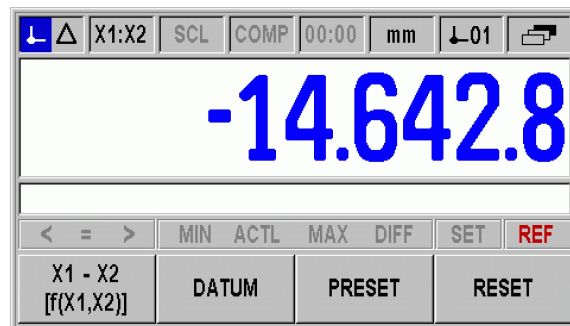

Fig. I.20 Standard screen with soft-key page 3

Setting the display value for one axis or for two axes in the X1 or X2 display mode

- ▶ Select soft-key page 3 on the standard screen.
- ▶ Select display mode X1 or X2 (see "Axis display mode" on page 27).
- ▶ If necessary, press the DATUM soft key to select the datum you want to set.
- ▶ To reset the display value to zero, press the RESET soft key or apply a signal to **pin 2** of connection X41. As an alternative, you can use the numeric keys to enter the number **zero** and press ENTER to confirm your entry.
- ▶ You can also set any desired display value by entering the new value with the **numeric keypad**. As a result, the SET symbol in the status display starts flashing in red. Press the ENTER key to confirm the entered numerical value.
- ▶ To set the display value to the preset value for the datum point (see "Value for datum point" on page 36), press the PRESET soft key. As an alternative, you can apply a signal to **pin 3** of connection X41.



Setting the display value for two axes in display mode X1:X2 (applies to X1+X2, X1-X2, f(X1,X2))

- ▶ Select soft-key page 3 on the standard screen.
- ▶ Select display mode X1:X2 (see "Axis display mode" on page 27).
- ▶ If necessary, press the DATUM soft key to select the datum you want to set.
- ▶ To **reset the display value of both axes to zero**, press the RESET soft key or apply a signal to **pin 2** of connection X41. As an alternative, you can use the numeric keys to enter the number **zero** and press ENTER to confirm your entry. Depending on the formula programmed for the coupled position, the display value does not necessarily need to be zero.
- ▶ You can also set axis **X1** to any desired display value by entering the new value with the **numeric keypad**. As a result, the SET symbol in the status display starts flashing in red. Press the ENTER key to confirm the entered numerical value. The display value of axis **X2** is automatically reset to the value **zero**.
- ▶ To set axis **X1** to the preset value for the datum point (see "Value for datum point" on page 36), press the PRESET soft key. The display value of axis **X2** is automatically reset to the value **zero**. As an alternative, you can apply a signal to **pin 3** of connection X41.

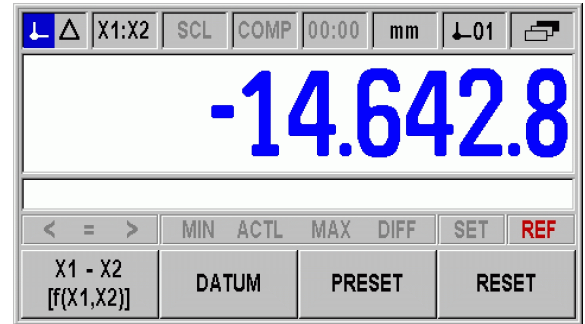

Fig. I.21 Standard screen with soft-key page 3

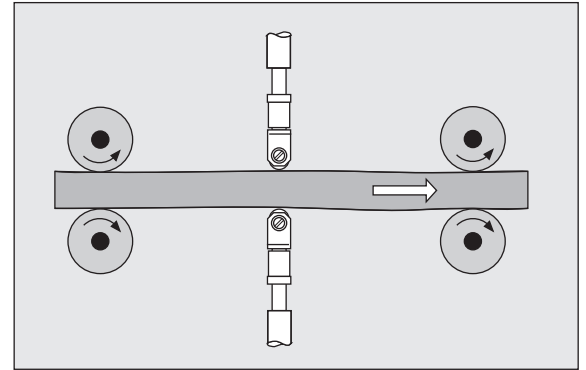

Fig. I.22 Sum or difference display

Calling the JOB SETUP menu

The ND 287 offers two categories for setting up operating parameters: JOB SETUP and INSTALLATION SETUP.

- The JOB SETUP parameters are used to accommodate specific machining requirements for each job.
- The INSTALLATION SETUP menu is used to establish encoder, display and communication parameters (see "INSTALLATION SETUP menu" on page 70).

To call the JOB SETUP menu:

- ▶ Press the SETUP soft key to open the JOB SETUP menu.

When in the JOB SETUP menu, the following soft keys will be available (see Fig. I.23):

- **INSTALLATION SETUP**
Press to begin accessing the INSTALLATION SETUP parameters (see "INSTALLATION SETUP menu" on page 70).
- **IMPORT/EXPORT**
Operating parameter information can be imported or exported over the serial port. (See "Serial data transfer with the Import or Export function" on page 102). Press this soft key to call the two following soft keys:
 - ▶ Press IMPORT to download operating parameters from a PC.
 - ▶ Press EXPORT to upload the current operating parameters to a PC.
- ▶ To exit, press the C key.
- **HELP**
This soft key will open on-line help.

Press the NAVIGATION key to move through the pages of menu parameters. To view and change menu parameters, use the UP/DOWN arrow key to highlight the parameter of interest and press the ENTER key.

On the following pages you will find more information on the menu parameters.

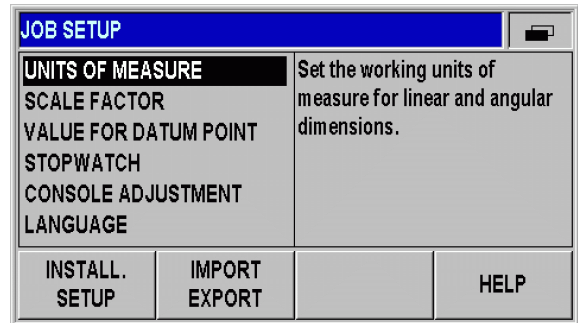

Fig. I.23 JOB SETUP menu

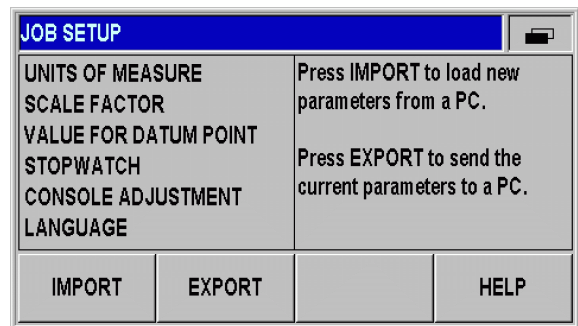

Fig. I.24 JOB SETUP menu



Unit of measure

The UNITS OF MEASURE form is used to specify the preferred display units and formats for linear and angular measurements. The ND 287 powers up with these settings in effect.

In the LINEAR field, define the unit of measure for linear measurement:

- ▶ In the JOB SETUP menu, select UNITS and press the ENTER key to open the form.
- ▶ Use the MM/INCH soft key to switch between MM and INCHES. This can be performed in either Actual Value or Distance-To-Go mode.

In the ANGULAR field, define the format and input mode for angles.

- ▶ Press the ANGLE soft key to switch between DECIMAL DEGREES, RADIANS and DMS (degrees/minutes/seconds).

The defined unit of measure is shown in the status bar on the standard screen.

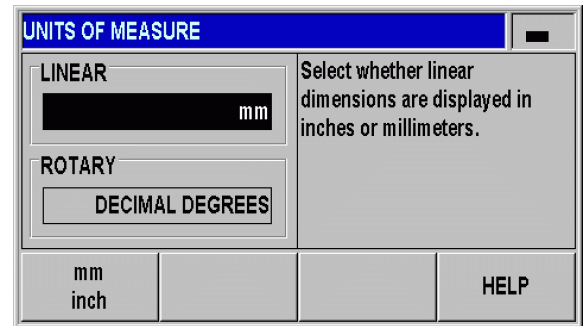

Fig. I.25 Unit of Measure



Scaling factor

The scaling factor may be used to scale the part up or down. All encoder movements are multiplied by the scaling factor.

- A scaling factor of 1.0 creates a part with the exact size as dimensioned on the print.
- A scaling factor > 1 enlarges the workpiece.
- A scaling factor < 1 reduces the workpiece.

To define the scaling factor:

- ▶ In the JOB SETUP menu, select SCALE FACTOR and press the ENTER key to open the form.
- ▶ The ON/OFF soft key is used to disable the current scaling factors.
- ▶ Use the numeric keys to enter a number greater than zero if a scaling factor is active. The number range is 0.100000 to 10.000000. When the scaling factor is a value other than 1, the scaling symbol SCL is shown in black in the status bar.

The settings for the scaling factor will be retained on a power cycle.



- The scaling factor can only be activated for axes with linear encoders.
- **Mirror:** A scaling factor of **-1.00** will produce a mirror image of the part. You can both mirror and scale a part at the same time.

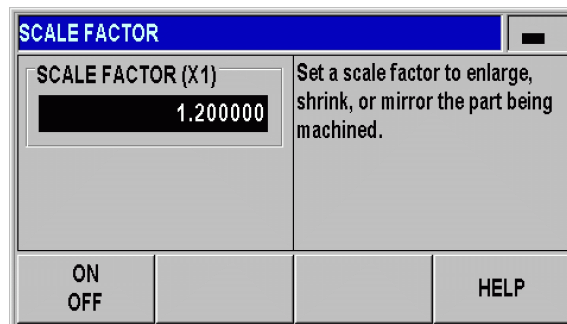

Fig. I.26 Scaling factor



Value for datum point

This form is used to set a value for a datum point (see Fig. I.27).

- ▶ In the JOB SETUP menu, select VALUE FOR DATUM POINT and press the ENTER key to open the form.
- ▶ Enter the value and press ENTER to confirm your entry.
- ▶ If you want to set the display value to this value, press the PRESET soft key on the standard screen (see "Datum setting" on page 31) or activate **pin 3** at D-sub connection X41 (see "Switching inputs at D-sub connection X41" on page 94).

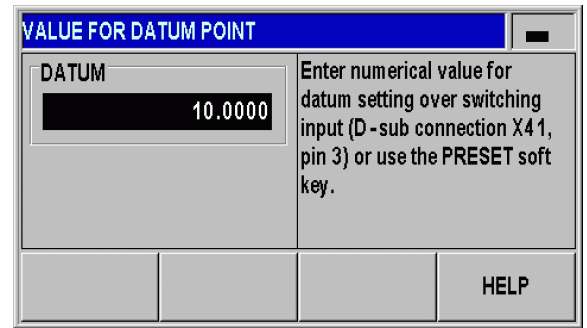

Fig. I.27 Value for datum point

Stopwatch

The stopwatch shows the hours (h), minutes (m), seconds (s). It operates like a stop watch showing elapsed time. The clock starts timing from 0:00:00.

The ELAPSED TIME field shows the total accumulated time from each interval (see Fig. I.28).

- ▶ In the JOB SETUP menu, select STOPWATCH and press the ENTER key to open the form.
- ▶ Press the START/STOP soft key. The ND 287 shows the status field RUNNING and the elapsed time. Press it again to stop time from elapsing.
- ▶ Press the RESET soft key to reset the elapsed time. Resetting will stop the clock if it is running (STOPPED).



Fig. I.28 Stopwatch



- All stopwatch functions (START, STOP, and RESET) are applied immediately.
- The **status bar** shows minutes and seconds for an elapsed time of less than 1 hour. Hours and minutes are shown for a time of 1 hour or more.



Console adjustment

You can adjust the brightness of the ND 287's LCD display (see Fig. I.29):

- ▶ In the JOB SETUP menu, select CONSOLE ADJUSTMENT and press the ENTER key to open the form.
- ▶ Press the DECREASE or INCREASE soft key to adjust the brightness to your requirements.
- ▶ The DISPLAY SAVER setting is the amount of time the system is idle before the LCD is turned off. The idle time may be set from 30 to 120 minutes. The display saver can be disabled during the current power cycle by pressing the DISABLE soft key.



You can also use the UP or DOWN arrow key to adjust the LCD's brightness directly on the screen.

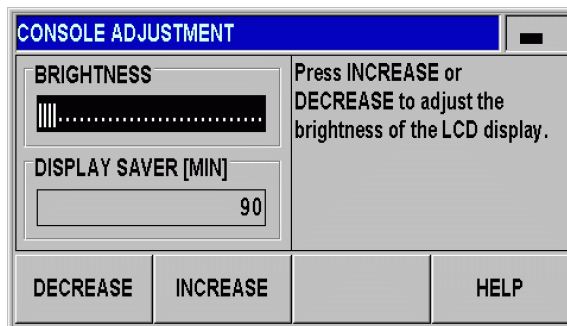

Fig. I.29 Console adjustment

Language

The ND 287 supports multiple languages. To change the language:

- ▶ In the JOB SETUP menu, select LANGUAGE and press the ENTER key to open the form.
- ▶ Press the LANGUAGE soft key until the desired language appears in the LANGUAGE field.
- ▶ Press ENTER to confirm your selection.



Fig. I.30 Language

Switching signals



Danger to internal components!

- The power supply of external circuits must comply with **EN 50178 requirements for low voltage electrical separation**.
- Connect inductive loads only with a **quenching diode parallel to the inductance**.



Danger to internal components!

Use only shielded cables and **connect the shield to the connector housing**.

- ▶ In the JOB SETUP menu, use the DOWN arrow key to select SWITCHING SIGNALS, and press the ENTER key to open the form.
- ▶ Press the ON/OFF soft key to activate/deactivate the trigger points.
- ▶ Using the numeric keys, enter the desired trigger limits **A1** and **A2**.

When the trigger limits defined by parameter are reached, the corresponding output becomes active. Output **A1** represents **pin 15** at D-sub connection **X41**, and output **A2** represents **pin 16**:

- **Pin 15** remains active as long as the measured value is **greater than or equal to A1**.
- **Pin 16** remains active as long as the measured value is **greater than or equal to A2**.

A separate output is available for trigger point **zero**. If the display value is **zero**, the position display unit always activates **pin 14** at D-sub connection X41. The **minimum signal duration** is **180 ms**.

The ND 287 constantly monitors the measuring signal, the input frequency, the data output, etc., and displays errors in the message line. If errors occur that seriously influence measurement or data output, the ND activates the switching output at **pin 19**. The output remains active until the error has been acknowledged. This makes it possible to **monitor proper function** during automated processes.



In the **Distance-To-Go** operating mode, the switching outputs **A1** (pin 15) and **A2** (pin 16) have a **different function** (see "Switching outputs at D-sub connection X41" on page 96).

SWITCHING SIGNALS	
TRIGGER LIMIT A1 3.5805	Set the trigger limits for output signals A1 and A2 at D-sub connection X41 (pin 15, pin 16).
TRIGGER LIMIT A2 3.6195	
ON OFF	HELP

Fig. I.31 Switching signals



Measured value output

With the measured value output feature, the current display values can be transmitted over the serial port. Output of the current display values is activated via a **switching signal at D-sub connection X41**, the command **CTRL B**, or the PRINT soft key (see "Measured Value Output" on page 114).

The effect the signal for measured value output has on the display value on the screen can be defined as follows:

- ▶ In the JOB SETUP menu, select MEASURED VALUE OUTPUT and press the ENTER key to open the form.
- ▶ Press the DISPLAY FREEZE soft key. Three different settings are available:
 - **CONCURRENT DISPLAY**: The display is not stopped during measured value output. The display value is the current measured value.
 - **FROZEN/CONCURRENT DISPLAY**: The display is stopped during measured value output and remains stopped while the switching input is active.
 - **FROZEN DISPLAY**: The display is stopped, but is updated by every measured value output.

The following figure illustrates the different settings for measured value output.

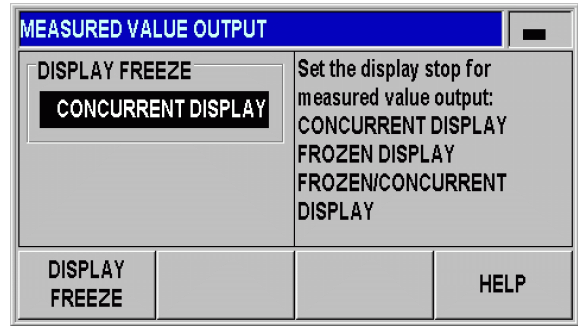
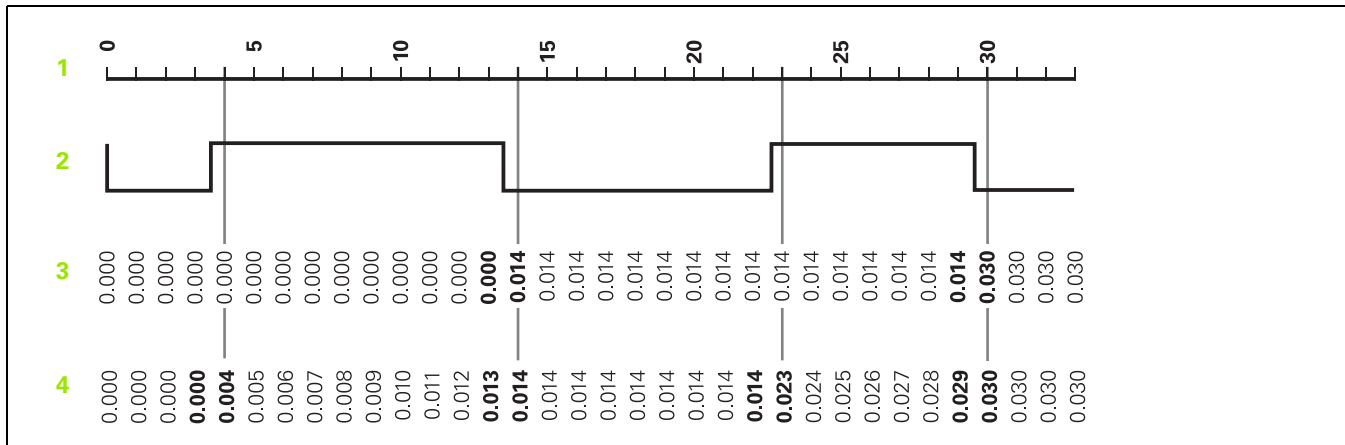

Fig. I.32 Measured value output



- 1 Position
- 2 Latch signal
- 3 Frozen display
- 4 Frozen/concurrent display

For more information on measured value output, refer to Page 114.



Function of external inputs



Danger to internal components!

- The power supply of external circuits must comply with **EN 50178 requirements for low voltage electrical separation**.
- Connect inductive loads only with a **quenching diode parallel to the inductance**.



Danger to internal components!

Use only shielded cables and **connect the shield to the connector housing**.

Use FUNCTION EXT. INPUTS in the JOB SETUP menu to determine the ND 287's reaction to the external inputs at connection X41 (see "Switching inputs at D-sub connection X41" on page 94).

- ▶ In the JOB SETUP menu, select FUNCTION EXT. INPUTS and press the ENTER key to open the form.
- ▶ Press the VERSION soft key. Two different versions are available:
 - **VERSION 1:** You can externally activate the **minimum/maximum measurement for measurement series** if the signal at **pin 6** remains permanently **LOW**. The SELECT DISPLAY soft key for selecting the display mode becomes ineffective. **Pin 7** sets the display to MIN, **pin 8** to MAX and **pin 9** to DIFF. The display can only be set to ACTL if either none of the pins 7, 8 or 9 or more than one of the pins carries a signal. A signal (pulse) at **pin 5** starts a **new series of measurements** if the signal at pin 6 is permanently LOW.
 - **VERSION 2:** If pins 5, 6, 7, 8 or 9 are activated, the **display modes are switched to operation with two axes**. **Pin 6** switches to axis **X1**, **pin 7** to axis **X2**, **pin 8** to the sum of the two axes **X1+X2**, **pin 9** to the difference between the two axes **X1-X2** and **pin 5** switches to the definable relationship between the two axes **f(X1,X2)**, see "Formula for coupled position" on page 79.

An overview of the switching inputs and outputs is provided on Page 94.

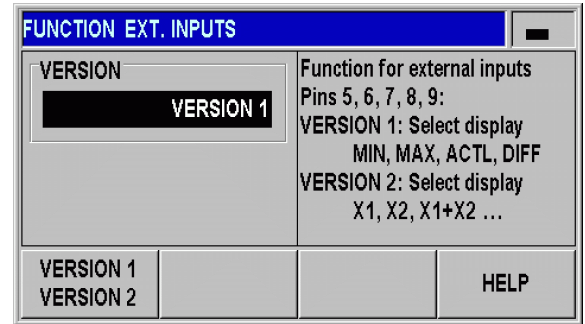

Fig. I.33 Function of external inputs



Compensation using a reference part

Select the REFERENCE PART COMP. menu item to activate temperature compensation using a reference part. Prerequisites:

- A temperature sensor is connected to encoder input X2.
- For the temperature sensor, you have set the ENCODER TYPE field in the ENCODER SETUP menu to COMPENSATION and entered the following encoder parameters, see "Setting up the encoder", page 72:
 - Calibration pair of values
 - Correct thermal expansion coefficient
 - Reference temperature
- The compensation value C is calculated as follows:

$$C = ND * E * (T - T_r)$$
- ND: Nominal dimension of reference part
- E: Expansion coefficient
- T: Temperature currently being measured
- T_r: Reference temperature

To activate the compensation:

- ▶ In the JOB SETUP menu, select REFERENCE PART COMP. and press the ENTER key to open the form.
- ▶ Enter the known nominal dimension of the reference part in the NOMINAL DIMENSION field.
- ▶ Press the ON/OFF soft key to activate the temperature compensation using a reference part in the MEASURE REF. PART field.

To measure the reference part:

- ▶ Press the MEASURE REF. PART soft key in the 3rd soft key row of the standard screen. The ND 287 displays the current temperature value on the left side of the message line, and the entered nominal dimension of the reference part on the right side.
- ▶ Insert your reference part and press either the ZERO soft key or the NOMINAL DIMENSION soft key, depending on whether you want to display the test objects' deviations from zero or from the nominal dimension.

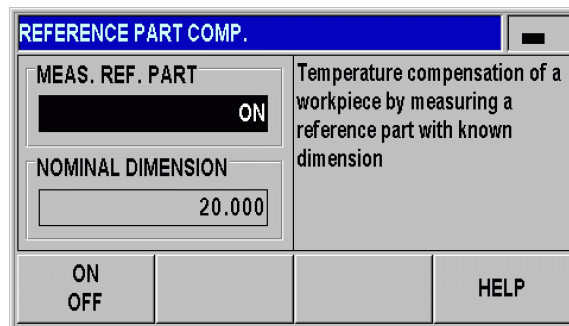

Fig. I.34 Compensation using a reference part

I – 5 Series of Measurements and Statistical Process Control

Functions

In addition to displaying measured values, the ND 287 can record and evaluate measured values as a **series of measurements**, and can perform **Statistical Process Control (SPC)**.

You can record **series of measurements** with up to **10000 measured values per connected axis**. The recording of the measured values can be initiated **manually, externally** or **according to time**. After the series of measurements has been recorded, you can immediately evaluate it on the ND 287 and display it as a **table or a graph**. The measured values can also be exported.

For **statistical process control**, the ND 287 can store up to **1000 measured values** in a **non-volatile FIFO memory**. After the required parameters have been defined and SPC has been started, **samples** of the measured values to be monitored are recorded. After a sufficient number of measured values has been recorded, the measured values accumulated so far can be evaluated. In addition to displaying the measured values, basic statistical data and a **histogram**, the ND 287 can also calculate and display the **process capability indices Cp** and **Cpk** as well as various **quality control charts**. For fundamentals on quality capability characteristics, refer to **ISO 21747**.

Switching between series of measurements and SPC mode

To switch between the MEAS. SERIES and SPC mode:

- ▶ Press the MEAS. SERIES [SPC] or SPC [MEAS. SERIES] soft-key (depending on which of the two soft keys is displayed) in the first soft-key row of the standard screen.
- ▶ This opens the SERIES OF MEASUREMENTS or SPC - STATISTICAL PROCESS CONTROL menu.
- ▶ To switch the mode, press the MEAS. SERIES [SPC] or SPC [MEAS. SERIES] soft key.

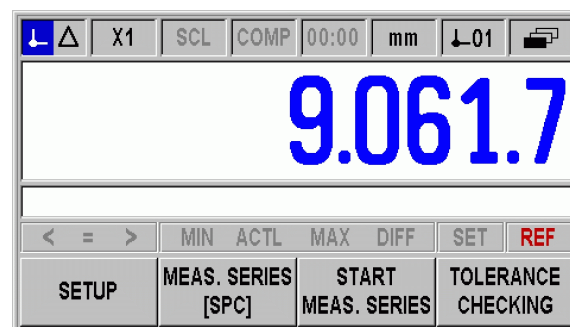

Fig. I.35 Measurement Series [SPC] mode



Calling the SERIES OF MEASUREMENTS menu

All parameters required for a series of measurements and the possibility of analyzing a previously recorded series of measurements are provided by the SERIES OF MEASUREMENTS menu.

- ▶ To call the SERIES OF MEASUREMENTS menu, press the MEAS. SERIES [SPC] soft key in the first soft-key row of the standard screen.
- ▶ Use the MEAS. SERIES ANALYSIS, MEAS. SERIES SETUP, MEAS. SERIES DISPLAY and RECORD MODE parameters to define further settings.

In the following sections you will find more detailed information on the menu parameters.

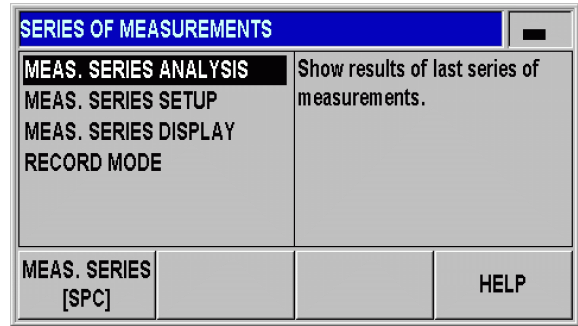

Fig. I.36 SERIES OF MEASUREMENTS menu

Analysis of series of measurements

The ND 287 provides the following possibilities for analyzing the recorded series of measurements:

- ▶ Call the SERIES OF MEASUREMENTS menu.
- ▶ Select MEAS. SERIES ANALYSIS. This opens an overview of the **statistical data** of the series of measurements: Number of measured values, maximum and minimum measured value, difference (MAX-MIN, also referred to as **range**), average value and standard deviation.
- ▶ If you have recorded the measured values of both axes, you can switch between the measured-value analyses of the two axes with the X1 [X2] soft key.
- ▶ Press the EXPORT soft key to transfer the recorded data to a PC.
- ▶ Press the GRAPH soft key to call a graphic display of all measured values, including the minimum, maximum and average values of the measurement series. If the sorting and tolerance checking mode is active, the ND 287 also enters the sorting limits into the graph.
- ▶ Press the MEASURED VALUES soft key to open a table with all recorded values. The measured values are listed in table format (24 measured values per page). If the sorting and tolerance checking mode is active, all measured values that are outside the sorting limits are displayed in red in the table.
- ▶ Use the PAGE UP or PAGE DOWN key to scroll through the table one page at a time.
- ▶ Press the STATISTICAL DATA soft key to return to the overview of statistical data.

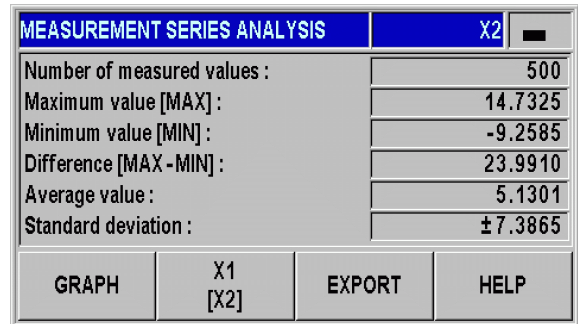

Fig. I.37 Statistical data of series of measurements

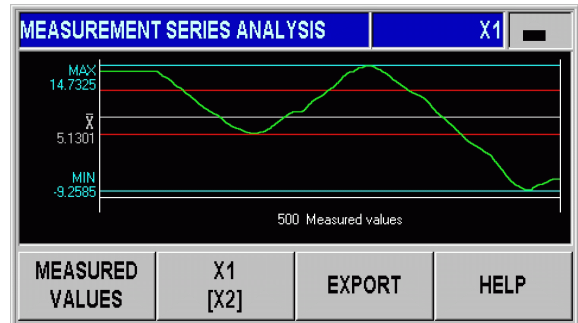

Fig. I.38 Graph



Setting up a series of measurements

To define the parameters of the series of measurements:

- ▶ Call the SERIES OF MEASUREMENTS menu.
- ▶ Select MEAS. SERIES SETUP.
- ▶ In the RECORD MEAS. VALUES field, activate or deactivate measured-value recording for a series of measurements.
- ▶ In the RECORD field, select the trigger for recording the measured values of a series of measurements. Press the RECORD soft key to select one of the following possibilities:
 - Sampling interval
 - External signal at connection X41 (pin 22 or 23)
 - ENTER key
- ▶ Press the DOWN arrow key or the NAVIGATION key to display further parameters.



The ND 287 can store a maximum of 10000 measured values per axis. The measured values recorded in a series of measurements will only be retained in memory until power is switched off.

If you have selected **EXTERNAL SIGNAL** or **ENTER** key, another parameter needs to be defined:

- ▶ In the NO. MEAS. VALUES field, you enter the number of measured values for the series of measurements. If you enter the value zero, the ND deactivates the RECORD MEASURED VALUES function.

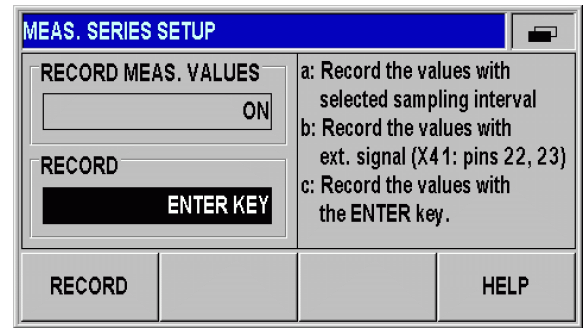

Fig. I.39 Setting up a series of measurements

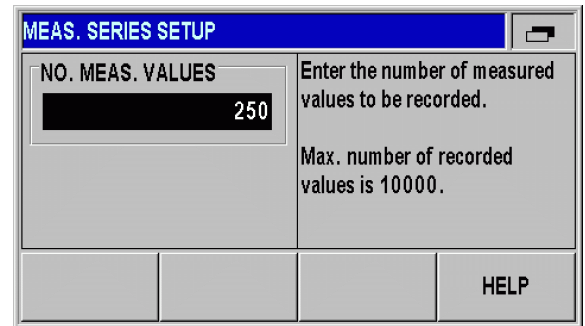

Fig. I.40 Setting up a series of measurements



If you have selected **SAMPLING INTERVAL**, the two following parameters in the second soft-key row are available for the exact definition of the interval:

- ▶ In the TIME SLOT field, define the duration of the series of measurements in hours/minutes/seconds. Use the ← and → soft keys to move from hours to minutes and seconds, and vice versa. Use the numeric keys to enter the desired value. The maximum possible duration of a measurement series is **999 hours, 59 minutes and 59 seconds**.
- ▶ In the SAMPLING INTERVAL field, enter the amount of time until a measured value is recorded. Press the DECREASE or INCREASE soft key to decrease or increase the value shown in the field: 20 ms to 80 ms in increments of 20 ms, 100 ms to 900 ms in increments of 100 ms, 1 s to 9 s in increments of 1 s and 10 s to 50 s in increments of 10 s, 1 min to 9 min in increments of 1 min and 10 min to 30 min in increments of 10 min.
- ▶ On the basis of the settings you defined for the sampling interval, the ND 287 calculates the number of measured values for the series of measurements and displays it in the NO. MEAS. VALUES field.



The measured values can be sorted and the sorting result can be displayed in color during the series of measurements in order to intervene, if required (see "Sorting and Tolerance Checking" on page 58).

MEAS. SERIES SETUP			
TIME SLOT [H.MIN.SEC.]	0. 00. 30	Set the sampling interval for measured value recording (min. 20ms, max. 60s).	
SAMPLING INTERVAL	60 ms	Max. number of recorded values is 10000.	
NO. MEAS. VALUES	500		
DECREASE	INCREASE		HELP

Fig. I.41 Setting up a series of measurements



Defining the display for a series of measurements

In the SERIES OF MEASUREMENTS menu, select MEAS. SERIES DISPLAY. Then press the DISPLAY MEAS. SER. soft key to select the value to be displayed while a series of measurements is being performed:

- ACTL DISPLAY: Current measured value is displayed.
- MIN DISPLAY: Minimum value of a series of measurements is displayed.
- MAX DISPLAY: Maximum value of a series of measurements is displayed.
- DIFF DISPLAY: Difference MAX - MIN (i. e. the range) is displayed.

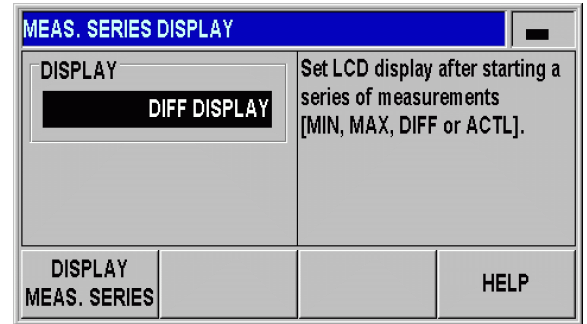

Fig. I.42 Display for series of measurements

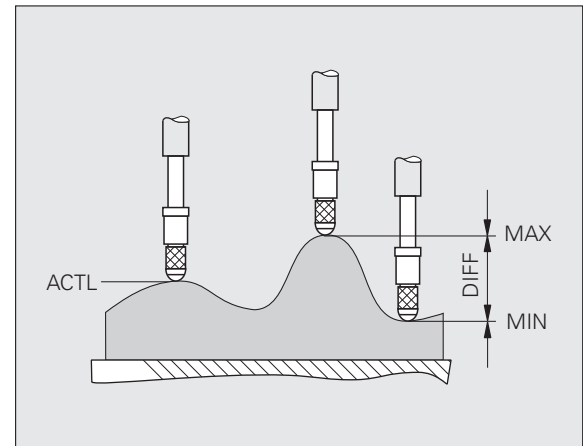

Fig. I.43 MIN, MAX and DIFF of a curved surface

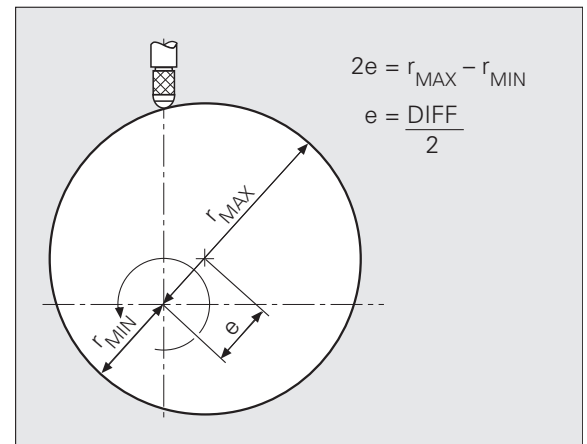

Fig. I.44 Series of measurements for determining eccentricity



Defining the record mode

The ND 287 can record different types of measured values:

- ▶ In the MEAS. SERIES menu, select the RECORD MODE menu item.
- ▶ Press the RECORD MEAS. SERIES soft key to select the mode of recording:
 - ACTL DISPLAY: Current measured value is recorded.
 - MIN DISPLAY: Minimum values of a series of measurements are recorded.
 - MAX DISPLAY: Maximum values of a series of measurements are recorded.
 - DIFF DISPLAY: Differences MAX - MIN (i. e. the ranges) are recorded.

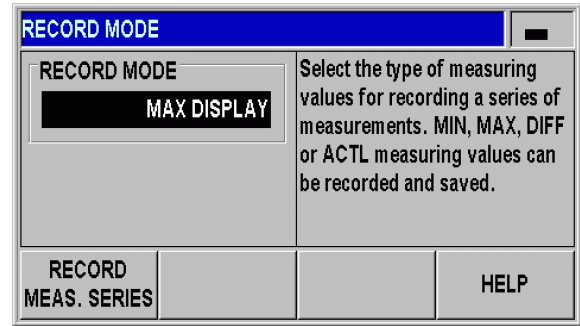

Fig. I.45 Mode of recording



Starting and stopping a series of measurements

- ▶ Select the first soft-key page of the standard screen.
- ▶ Press the START MEAS. SERIES soft key to start a series of measurements. If the START SPC soft key is displayed on the screen, press the SPC [MEAS. SERIES] soft key to open the SPC menu, and then press the SPC [MEAS. SERIES] soft key to switch to the SERIES OF MEASUREMENTS mode (see "Switching between series of measurements and SPC mode" on page 42). If the ND 287 is configured for two axes and the display mode X1:X2 is **not** active, then the ND records the values for both axes simultaneously after the series of measurements has been started. The ND can store up to 10000 values. The measured-value counter is shown on the left side of the message line. It shows the number of the current value being measured and the total number of values to be measured, e.g. 0/50.
- ▶ If required, you can switch the display mode during the series of measurements by pressing the SELECT DISPLAY soft key (see "Defining the display for a series of measurements" on page 46). The currently active display mode is highlighted in the status display: MIN, ACTL, MAX or DIFF.
- ▶ You can stop the current series of measurements at any time by pressing the STOP MEAS. SERIES soft key. When the defined number of measured values has been reached, the ND stops the series of measurements automatically.
- ▶ The DYNAMIC RESET soft key appears only if you use the ENTER key or an external signal for saving and if you have selected the MIN, MAX or DIFF recording mode. If you press this soft key, the MIN, MAX and DIFF values are reset to zero.

All parameters required for a series of measurements and the possibility of analyzing a previously recorded series of measurements are provided by the SERIES OF MEASUREMENTS menu.



- When a series of measurements is started, the MIN/MAX/DIFF memory is automatically reset, and the measured values of the last recorded series of measurements are deleted.
- A new series of measurements cannot be started until the current series of measurements has been concluded.

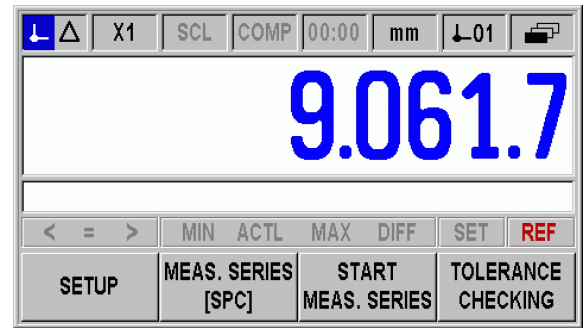

Fig. I.46 Standard screen with soft-key page 1

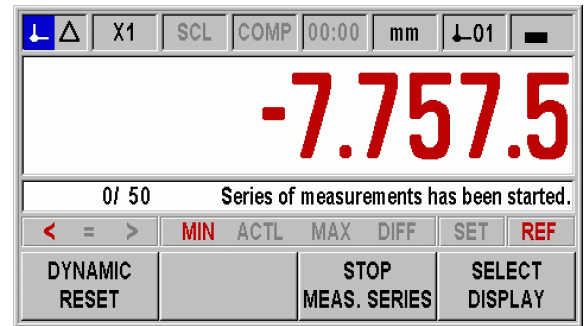

Fig. I.47 Series of measurements has been started



Calling the SPC menu

All parameters required for Statistical Process Control (SPC) and the possibility of analyzing the current or completed SPC are provided by the SPC menu.

- ▶ To call the SPC menu, press the SPC [MEAS. SERIES] soft key in the first soft-key row of the standard screen.
- ▶ Use the SPC ANALYSIS, SPC SETUP and DELETE STATISTIC parameters to define further settings.

In the following sections you will find more detailed information on the menu parameters.

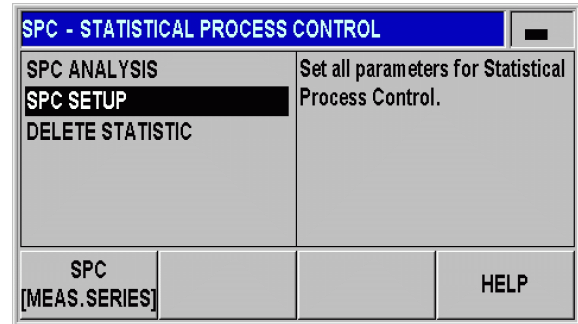

Fig. I.48 SPC menu

SPC analysis

The ND 287 provides the following possibilities for analyzing the measured values recorded during statistical process control:

- ▶ Call the SPC menu.
- ▶ Select SPC ANALYSIS. This opens an overview of the **SPC data**: Number of measured values, minimum and maximum measured values, difference MAX-MIN, average value and standard deviation. This data is based on the measured values from the FIFO memory. At the upper right of the screen the ND displays the **sample counter x/y z**, e.g. "1/5 51". **x** is the number of the measurement that is currently being performed for the current sample (the total number of measurements to be performed for each sample is indicated in DATA PER SAMPLE), **y** is the number of measured values per sample (indicated in DATA PER SAMPLE), and **z** is the total number of measurements that have been recorded so far (maximum of $z = \text{product of } x \text{ multiplied by } y$). You can call the analysis function immediately after switching the ND 287 on. The number of recorded values depends on the sample settings you have defined for SPC (see "Samples" on page 52).
- ▶ Press the EXPORT soft key to transfer the recorded data to a PC.
- ▶ Press the MEASURED VALUES soft key to open a table with all recorded values. The measured values are listed in table format (24 measured values per page).
- ▶ Use the PAGE UP or PAGE DOWN key to scroll through the table one page at a time.
- ▶ Press the leftmost soft key to toggle through all evaluated diagram types: Graph, histogram, control chart \bar{x} , control chart **s** and control chart **r**. Press the C key to return to the SPC menu.

SPC ANALYSIS		X1
Number of measured values :		51
Maximum value [MAX] :		9.3775
Minimum value [MIN] :		1.1600
Difference [MAX - MIN] :		8.2175
Average value :		4.1982
Standard deviation :		± 1.7601

Fig. I.49 SPC data

- ▶ Press the GRAPH soft key to call a graphic display of all measured values, including the lower tolerance limit **LT**, upper tolerance limit **UT**, nominal value (mean tolerance value) **NV** and the **average value \bar{x}** . The graph shows the **last 30 measured values**. Use the \leftarrow and \rightarrow soft keys to scroll the graph forward or backward by 25 measured values at a time.
- ▶ Press the HISTOGRAM soft key to display a histogram of the measured values. The histogram sorts all recorded values into **10 classes**. The histogram also shows the lower tolerance limit **LT**, the upper tolerance limit **UT**, the nominal value (mean tolerance value) **NV** and the **average value \bar{x}** . When a sufficient number of measured values (at least half of the product of NUMBER OF SAMPLES multiplied by DATA PER SAMPLE) is available after SPC has been restarted, the ND 287 also draws the **probability density curve** in the histogram. The ND 287 calculates the **process capability indices C_p and C_{pk}** and displays them to the right of the histogram. These values can be used to estimate the reliability of the process within the defined specifications.
- ▶ Press the **CONTROL CHART \bar{x}** soft key to display the control chart for the **average value (\bar{x} chart)**. The average value of each sample is entered in this control chart. The control chart shows up to 30 of the last values. Use the \leftarrow and \rightarrow soft keys to scroll the graph forward or backward by 25 measured values at a time. The control chart also shows the lower control limit for the average value **LCL \bar{x}** , the upper control limit for the average value **UCL \bar{x}** and the **average value of all measured values $\bar{\bar{x}}$** . The violation of lower or upper control limit and the position of the individual average values are important for the analysis of this control chart. For example, it is interesting to check whether a trend or run is visible. For more information, please refer to appropriate technical literature or ISO 21747.



Fig. I.50 Graph

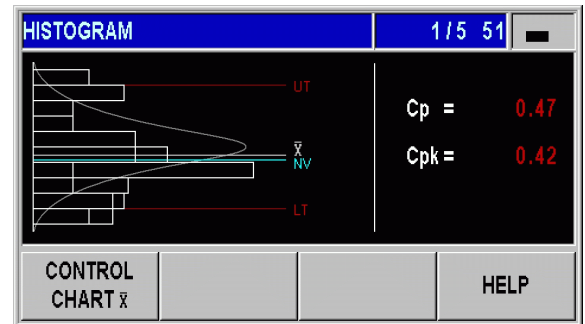

Fig. I.51 Histogram

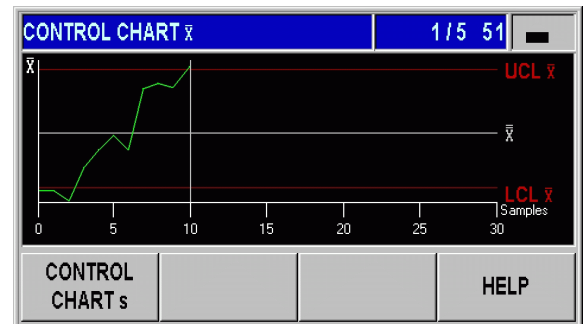

Fig. I.52 Control chart \bar{x}

- ▶ Press the CONTROL CHART **s** soft key to display the control chart for **standard deviation s (s chart)**. The standard deviation **s** of each sample is entered in this control chart. The control chart shows up to 30 of the last values. Use the \leftarrow and \rightarrow soft keys to scroll the graph forward or backward by 25 measured values at a time. The control chart also shows the upper control limit for the standard deviation **UCL s**, and the average value of the standard deviations \bar{s} . The ND also shows the calculated value \bar{s} .
- ▶ Press the CONTROL CHART **r** soft key to display the **chart r**. The range **r** is the difference between the smallest and the largest value of a sample. It is a measure of the statistical spread of the process. The chart shows up to 30 of the last values. Use the \leftarrow and \rightarrow soft keys to scroll the graph forward or backward by 25 measured values at a time. The control chart also shows the upper control limit for the range **UCL r**, and the average value of the ranges \bar{r} . The ND also shows the calculated value \bar{r} .
- ▶ Press the SPC ANALYSIS soft key to return to the overview of statistical data.

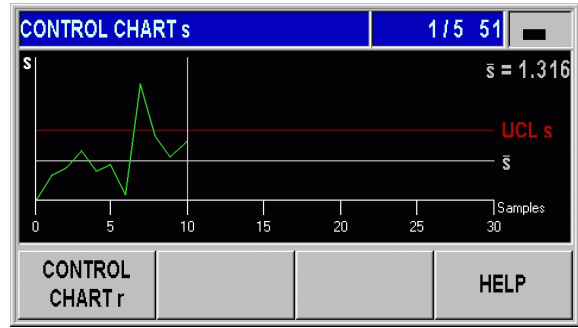

Fig. I.53 Control chart **s**



Fig. I.54 Control chart **r**



Setting up SPC

Call the SPC SETUP submenu to define the SPC parameters:

- ▶ Call the SPC menu.
- ▶ Select SPC SETUP. This opens the SPC SETUP submenu. The following parameters for setting up SPC are available:
 - SAMPLES
 - TOLERANCES
 - CONTROL LIMITS
 - STATISTICAL DISTRIBUTION
 - RECORD VALUES

In the following sections you will find more detailed information on the menu parameters.

Samples



- In the sample parameters, you define the total number of measured values for statistical process control
- If you edit the values entered, the ND displays a **warning. In order to save the changes, the ND must clear the data stored in the FIFO memory.** Press the ENTER key to confirm, or press the C key to cancel.

To call the SAMPLES form:

- ▶ In the SPC SETUP submenu, select SAMPLES and press the ENTER key to open the form.
- ▶ Use the numeric keys to enter the desired value in the NUMBER OF SAMPLES field, and press the ENTER key to confirm. A minimum of **two** and a **maximum of 100** samples are allowed.
- ▶ Use the numeric keys to enter the number of measured values per sample in the DATA PER SAMPLE field. Press the ENTER key to confirm your entry. A **minimum of three** and a **maximum of ten** measured values per sample are allowed.
- ▶ If you edit the values entered, the ND displays a **warning. In order to save the changes, the ND must clear the data stored in the FIFO memory.** Press the ENTER key to confirm, or press the C key to cancel.

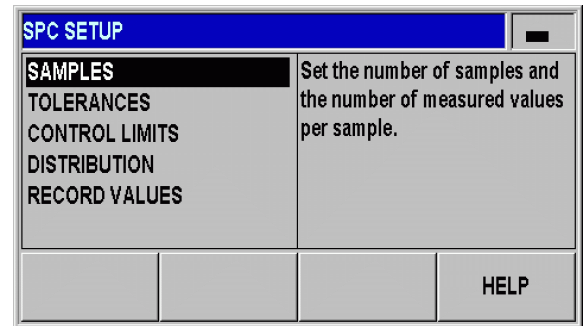

Fig. I.55 SPC SETUP submenu

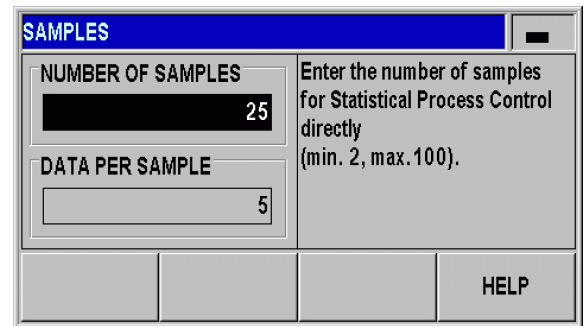

Fig. I.56 Samples



Tolerances



If you edit the values entered, the ND displays a **warning**. **In order to save the changes, the ND must clear the data stored in the FIFO memory.** Press the ENTER key to confirm, or press the C key to cancel.

In the TOLERANCES form, you define the tolerance limits for statistical process control:

- ▶ In the SPC SETUP submenu, select TOLERANCES and press the ENTER key to open the form.
- ▶ Use the numeric keys to enter the values for the **lower tolerance limit, the nominal value and the upper tolerance limit** in the LOWER LIMIT, NOMINAL VALUE and UPPER LIMIT fields. The values for the lower and upper tolerance limits correspond to the values for the lower and upper sorting limits. This means that the ND activates pins **17** or **18** at D-sub connection X41 if the limits are violated (see "Sorting and Tolerance Checking" on page 58).
- ▶ Press the RED, GREEN/[DISPL.BLUE] soft key to select whether the display value changes to the same color as the sorting symbols. Blue is the default setting for the color of the display value (see "Sorting and Tolerance Checking" on page 58).



Please note that the LOWER LIMIT must be less than the NOMINAL VALUE and the UPPER LIMIT, and the UPPER LIMIT must be greater than the NOMINAL VALUE.

TOLERANCES			
LOWER LIMIT	2.0000	Enter the upper tolerance limit (UT) for Statistical Process Control.	
NOMINAL VALUE	4.0000		
UPPER LIMIT	7.0000		
		RED, GREEN [DISPL. BLUE]	HELP

Fig. I.57 Tolerances



Control limits



- Incorrect control limits may increase the statistical spread of the process!
- If the measured value falls below or exceeds the control limits during statistical process control, the ND 287 displays a **warning** and switches the display to the respective control chart. The ND does not stop data acquisition.

In the CONTROL LIMITS form, you define the control limits for the control charts.

- ▶ In the SPC SETUP submenu, select CONTROL LIMITS and press the ENTER key to open the form.
- ▶ In the UCL \bar{x} and LCL \bar{x} fields, enter the values of the **upper and lower control limits for the \bar{x} chart** using the numeric keys.
- ▶ In the UCL s field, enter the value for the **upper control limit for the chart s** using the numeric keys.
- ▶ In the UCL r field, enter the value for the **upper control limit for the chart r** using the numeric keys.
- ▶ Press ENTER to confirm your entry.

Fig. I.58 Control limits UCL \bar{x} and LCL \bar{x}

Fig. I.59 Control limits UCLs and UCL r



Statistical distribution

The STATISTICAL DISTRIBUTION form allows you to define the calculation and graphic display of the distribution density curve in the histogram:

- ▶ In the SPC SETUP submenu, select STATISTICAL DISTRIBUTION and press the ENTER key to open the form.
- ▶ Press the DISTRIBUTION soft key to select the type of statistical distribution. For example, form and position tolerances, which have a natural lower limit (i.e. they cannot become less than zero), are processes with a left-hand limit. The following settings are available:
 - SYMMETRIC
 - LIMITED TO LEFT
 - LIMITED TO RIGHT

Measured value recording

The RECORD VALUES form allows you to define the trigger for recording the measured values for statistical process control:

- ▶ In the SPC SETUP submenu, select RECORD VALUES and press the ENTER key to open the form.
- ▶ Press the RECORD soft key to select one of the following settings in the RECORD field:
 - External signal at connection X41 (pin 22 or 23)
 - ENTER key



- The ND stores the data recorded during statistical process control in non-volatile memory. After the ND has been switched on again and SPC has been resumed, it will continue using the previously recorded data.
- The stored measured values can also be cleared. Use DELETE STATISTIC to clear all measured values from memory (see "Deleting SPC statistics" on page 56).

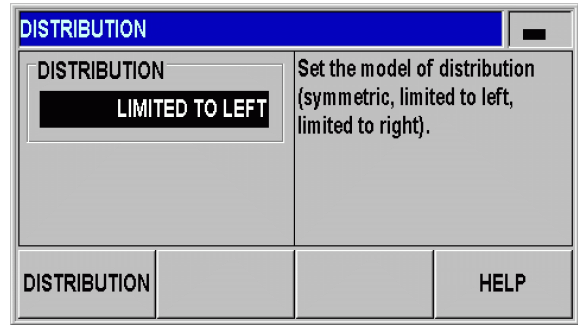

Fig. I.60 Statistical distribution

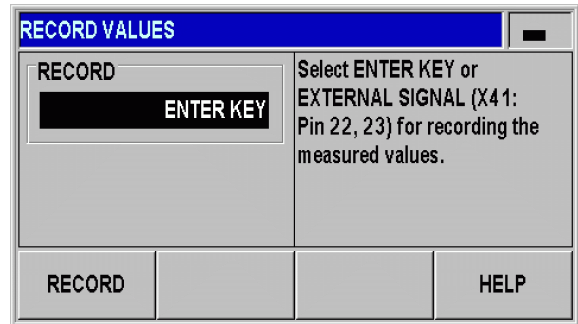

Fig. I.61 Measured value recording



Deleting SPC statistics

Use DELETE STATISTIC to delete all measured values stored in memory and to restart statistical process control:

- ▶ Call the SPC menu.
- ▶ Select DELETE STATISTIC and press the ENTER key to confirm, or press the C key to cancel. If you press ENTER, the ND will clear all recorded measured values from the FIFO memory.

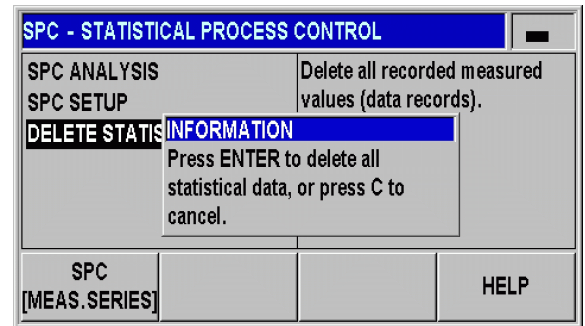

Fig. I.62 DELETE STATISTIC parameter

Starting and stopping SPC



Danger to workpiece!

- If the measured value falls below or exceeds the **control limits** during statistical process control, the ND 287 displays a **warning** and switches the display to the respective control chart. The ND does not stop data acquisition.
- If a measured value falls below or exceeds the defined **tolerance limits**, the ND displays the appropriate sorting symbols and the display value in red if you have activated this display color. **Pin 17** or **pin 18** at D-sub connection X41 are **active**.



- When you press START SPC, the ND 287 automatically resumes measured-value recording for the SPC that was last active. The previously measured sample values are retained in the FIFO memory. The memory is only cleared if you change the SPC settings in the SAMPLES or TOLERANCES form, or if you delete the measured values with the DELETE STATISTIC parameter (see "Deleting SPC statistics" on page 56).
- A **new SPC** cannot be started until the current SPC has been completed and the measured values recorded have been deleted (see "Deleting SPC statistics" on page 56).





The measured values and the data of the diagrams and control charts always apply to the **currently active display mode** (see "Axis display mode" on page 27):

- In display mode X1, the SPC data applies to the encoder at input X1.
- In display mode X2, the SPC data applies to the encoder at input X2.
- In display mode X1:X2, the SPC data applies to the defined coupled position value (X1+X2, X1-X2 or f(X1,X2)).

- ▶ Select the first soft-key page of the standard screen.
- ▶ Press the START SPC soft key to start the SPC function. If the START MEAS. SERIES soft key is displayed on the screen, press the MEAS. SERIES [SPC] soft key to open the SERIES OF MEASUREMENTS menu, and then press the MEAS. SERIES [SPC] soft key to switch to the **SPC** mode (see "Switching between series of measurements and SPC mode" on page 42). The **sample counter x y/z** counter is shown on the left side of the message line e.g. "1/ 51 125". **x** is the number of the measurement that is currently being performed for the current sample, **y** is the number of measurements that have been recorded so far, and **z** is the total number of measurements that has been entered.
- ▶ You can switch to an analysis of the current SPC at any time by pressing the SPC ANALYSIS soft key in order to analyze the measured values recorded so far (see "SPC analysis" on page 49).
- ▶ Press the DELETE MEAS. VALUE soft key to delete the measured value that was last recorded. Press the ENTER key to confirm, or press the C key to cancel.
- ▶ You can stop the current statistical process control at any time by pressing the STOP SPC key, and you can restart it at a later time.

All parameters required for statistical process control and the possibility of analyzing a previously recorded SPC are provided by the SPC menu.

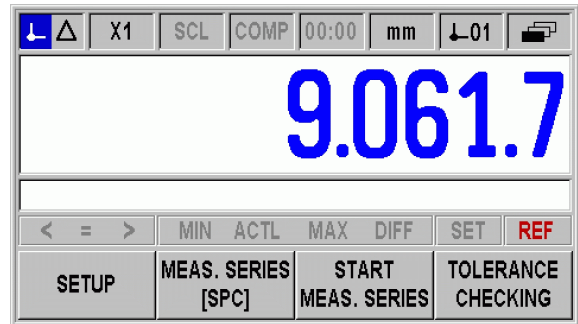

Fig. I.63 Standard screen with soft-key page 1

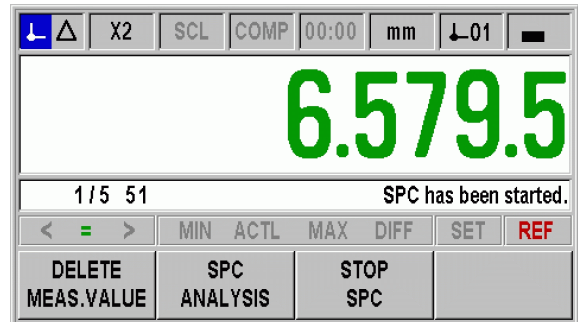

Fig. I.64 SPC has been started



I – 6 Sorting and Tolerance Checking

Sorting function

To sort the parts, the ND 287 compares the displayed value with an upper or lower sorting limit, and displays the sorting result in color as a display value and with the appropriate sorting symbol in the status display:

- **Green** symbol: =
Values that are displayed in green are within the sorting limits.
- **Red** symbol: < or >
Values that are displayed in red are smaller than the defined lower sorting limit or greater than the defined upper sorting limit.

At the same time, the sorting result is transmitted via two switching outputs (pins 17 and 18) at connection X41 (see "Switching outputs at D-sub connection X41" on page 96).

- **Pin 17** becomes active if the displayed value is smaller than the lower sorting limit.
- **Pin 18** becomes active if the displayed value is greater than the upper sorting limit.

The sorting and tolerance checking mode sorts the display value into one of the three following classes:

- **Within tolerance**
- **Above tolerance**
- **Below tolerance**

This means that the sorting limits correspond to the tolerance limits of SPC.

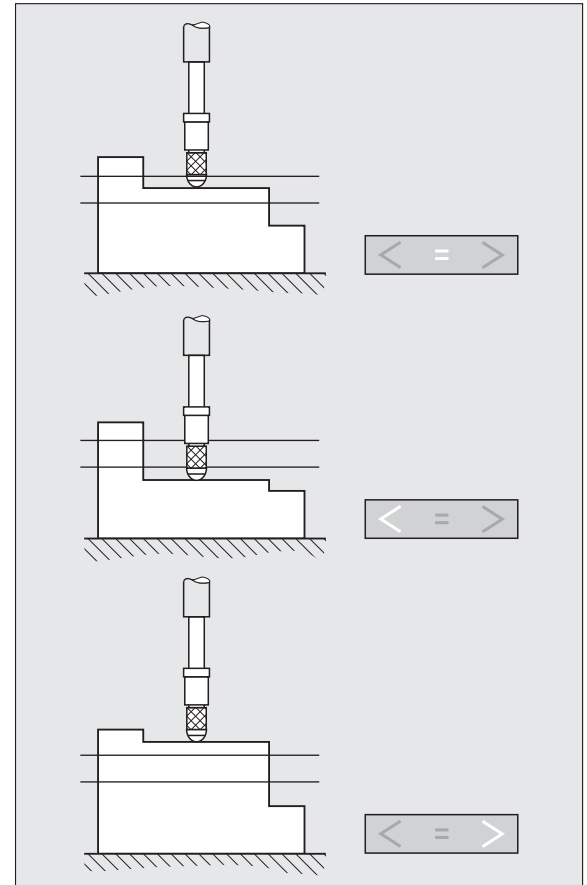

Fig. I.65 Status display for sorting and tolerance checking

Defining the sorting parameters

- ▶ Select the first soft-key page of the standard screen.
- ▶ Press the TOLERANCE CHECKING soft key to open the SORTING AND TOLERANCE CHECKING menu.
- ▶ In the SORTING field, press the ON/OFF soft key to activate or deactivate the sorting and tolerance checking mode.
- ▶ Press the RED, GREEN/[DISPL.BLUE] soft key to select the color of the display value in the sorting and tolerance checking mode. The default setting is blue.
- ▶ Use the numeric keys to enter the lower sorting limit in the LOWER LIMIT field.
- ▶ Enter the upper sorting limit in the UPPER LIMIT field.
- ▶ Press the ENTER key to confirm, or press the C key to cancel.



If all **sorting and tolerance checking symbols** light up, the upper sorting limit is smaller than the lower sorting limit. Change the respective parameters as described above.

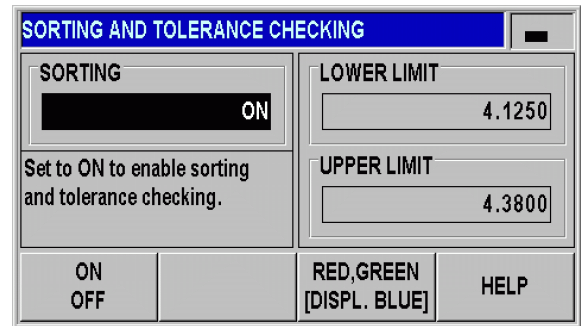

Fig. I.66 Sorting and tolerance checking



I – 7 Error messages

Overview

Various error messages may occur while you're using the ND 287. The ND 287 always stores the last error of each error category. You can acknowledge the error messages by pressing the **C key**, or by applying an **external signal to pin 2 of the D-sub connection X41**.



If a new error occurs before the last error has been acknowledged, the last error that has occurred will be displayed. After you have acknowledged the last error, the previous error will be displayed again. The ND always stores the last error of each error category for acknowledgment.

The following overview will help you to diagnose the errors as quickly as possible:

Error message	Error cause and corrective action
Error: Reference mark spacing	The reference mark spacing defined in ENCODER SETUP in the INSTALLATION SETUP menu does not match the actual spacing of the reference marks. ¹
DSR signal missing	The connected encoder has not sent a DSR signal.
EnDat connection problem	The ND has detected a communication problem with the encoder (only EnDat 2.1/2.2). Restart the encoder by unplugging and replugging the encoder cable, or switch the position display unit off and then back on. ¹
Error X1/X2: Input frequency too high	The input frequency at encoder input X1 or X2 is too high (e. g., when the traversing speed is too high). Use the diagnostic functions of the ND 287 to check the encoder. ¹
Error: Display overflow	The measured value to be displayed is too large or too small. Set a new datum or move within display range.
Position error X1/X2	Various reasons may cause the encoder (only EnDat 2.1/2.2) to set an error bit for axis X1/X2. Restart the encoder by unplugging and replugging the encoder cable, or switch the ND off and then back on. If the error recurs, use the ND's diagnostic functions for a more detailed diagnosis of the error. ¹
ERROR X1/X2: Encoder signal too small	The encoder signal at input X1 or X2 is too small (e. g., when the encoder is contaminated). Use the diagnostic functions of the ND 287 to check the encoder. ¹
Error X1/X2: Encoder signal too large	The encoder signal at input X1 or X2 is too large (e. g., when the encoder is mounted incorrectly). Use the diagnostic functions of the ND 287 to check the encoder. ¹
Interface commands too fast	Two commands for measured value output are sent in too close a succession.



Error message	Error cause and corrective action
Violation of control limits	A sample has violated the upper or lower control limit during analysis. Check the respective control chart and change the process settings, if required. When this error occurs, error pin 19 is not activated, but the ND automatically switches to the control chart that caused the error.

¹ These errors are important for the connected encoder. The error signal at pin 19 of connection X41 is active.



If all **sorting and tolerance checking symbols** light up, the upper sorting limit is smaller than the lower sorting limit. Change the respective parameters in the SORTING AND TOLERANCE CHECKING form.







**Installation,
Specifications**



II – 1 Installation and Electrical Connection

Items supplied

- ND 287 position display unit with the following connections:
 - **An encoder module** for connecting a HEIDENHAIN encoder with **11 μ App, 1 Vpp** or **EnDat 2.1/2.2 interface for axis X1** is a standard item supplied with the position display unit.
 - **Two serial connections** for data transmission: **RS-232-C/V.24 (X31)** and **USB type B (UART, X32)**
 - **Switching inputs and outputs at D-sub connection X41** for automated tasks
- 2.5 m long power cable with European plug
- Quick Reference Guide

Optional accessories

- Encoder module for connecting a HEIDENHAIN encoder with **11- μ App, 1-Vpp** or **EnDat 2.1/2.2** interface for a **second axis X2**
- **Analog module as input assembly X1 and/or X2** for an analog sensor with **± 10 V** voltage interface, preferably a **temperature sensor for axis-error compensation**
- Ethernet module (100baseT) for network connection via TCP/IP protocol
- Mounting base for installation in a 19-inch electrical cabinet
- Various adapter cables with D-sub connector for HEIDENHAIN encoders
- Length gauge with D-sub connector
- Data transmission cable for RS-232-C/V.24 interface
- Data transmission cable for USB interface

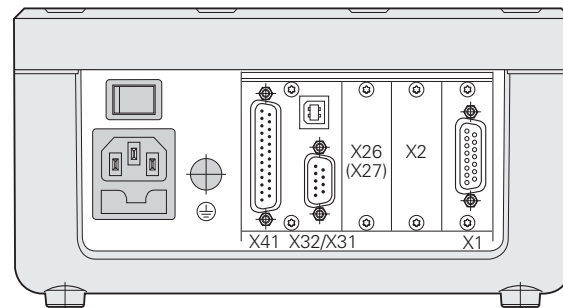

Fig. II.1 Connections

Mounting

Environmental conditions

Property	Value
Protection (IEC 60529)	IP 40 rear panel IP 54 front panel
Operating temperature	0° to 50 °C (32° to 122 °F)
Storage temperature	-40 ° to 85 °C (-40 ° to 185 °F)
Relative air humidity	Annual mean: < 75% In exceptional cases: < 90%
Weight	Approx. 2.5 kg (5.5 lb.)

Mounting location

Locate the ND 287 in a well ventilated area such that it may be easily accessed during normal operation.

ND 287 – Mounting and installation

M4 screws are used to secure the ND 287 from below. For the hole locations, see "Dimensions" on Page 138.

You can install the ND 287 in an electrical cabinet (see "Mounting base for installation in 19-inch electrical cabinet" on page 141) by using a mounting base (option). The dimensions of the position display unit allow you to install two units next to each other in a 19-inch cabinet (see "Dimensions" on page 138).

The ND 287 position display units are easily **stackable**. **Slots on the top** prevent the stacked units from being moved out of place.

The units can be stacked in either of the following two ways (see Fig. II.2):

- On top of each other at a front angle of 10°.
- Vertically on top of each other: Screw the front feet of the ND into the appropriate mounting holes.

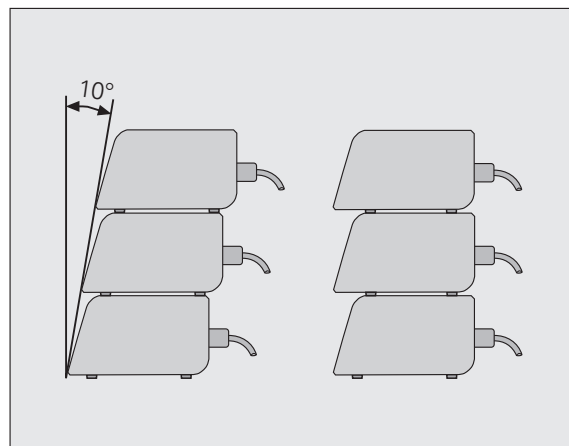

Fig. II.2 Alternatives for stacking the position display units

Electromagnetic compatibility/ CE compliance

The ND 287 fulfills the requirements for electromagnetic compatibility according to 2004/108/EC with respect to the generic standards for

- Noise immunity as per IEC 61000-6-2: Specifically:
 - ESD as per IEC 61000-4-2
 - Electromagnetic fields as per IEC 61000-4-3
 - Burst as per IEC 61000-4-4
 - Surge as per IEC 61000-4-5
 - Conducted disturbances as per IEC 61000-4-6
- Emission as per IEC 61000-6-4: Specifically:
 - For industrial, scientific and medical (ISM) equipment as per EN 55011
 - For information technology equipment as per IEC 55022 Class B



Electrical connection

Electrical requirements



Danger of electrical shock!

Unplug the power cord before opening the housing.
Connect a protective ground (see "Grounding" on page 67).
The protective ground connection must never be interrupted.



Danger to internal components!

Do not engage or disengage any connections while the unit is under power.
Use only original replacement fuses.

Type	Value
AC voltage	Between 100 and 240 V~
Power	Max. 30 W
Frequency	50/60 Hz
Fuse	2 x T500 mA

Wiring the power connector

The ND features a plug socket for a cable with European plug on the rear panel, see Fig. II.3:

Hot leads: L and N

Ground:

Minimum diameter of power connection cable: 0.75 mm²

Maximum cable length: 3 m

Grounding



Danger to internal components!

It is necessary to connect the ground terminal on the rear panel to the star point of machine ground.

Minimum cross-section of the connecting wire: 6 mm², see Fig. II.4.

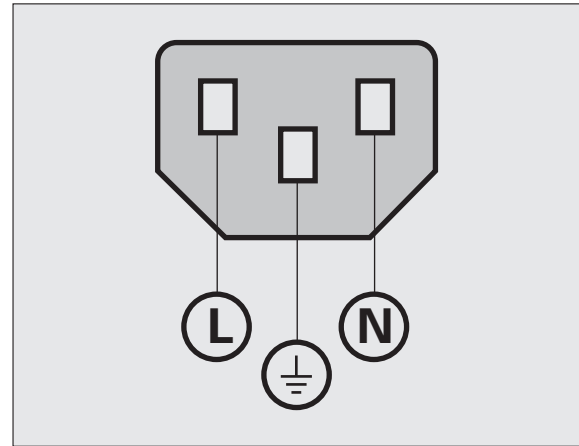

Fig. II.3 Wiring the power connector

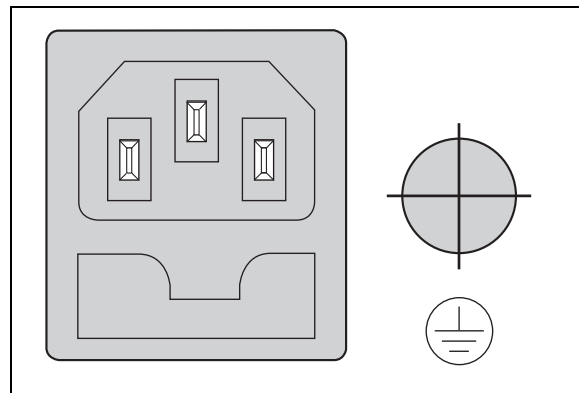

Fig. II.4 Power connection and protective ground terminal on the rear panel



Preventative maintenance or repair

No special preventative maintenance is necessary. For cleaning, wipe lightly with a dry lint-free cloth.



Danger of electrical shock!

- The position display unit must be repaired by qualified and authorized service technicians.
- See the last page of the Operating Instructions for our service department's contact data.

Connecting the encoders

The ND 287 operates with the following encoders:

- Incremental encoders with sinusoidal output signals (11 μ App or 1 Vpp interface)
- Absolute encoders with a bidirectional EnDat 2.1/2.2 interface. (When an EnDat 2.1 interface is used, the resolution is limited, because the incremental signals are ignored.)
- Optional: Analog sensor with ± 10 -V interface

The slots for the encoder input assemblies on the rear panel are designated X1 and X2.



Danger of electrical shock!

The interfaces X1 and (optionally) X2 comply with the requirements of EN 50 178 for **low voltage electrical separation**.

Do not engage or disengage any connections while the unit is under power.

D-sub connection X1/X2 (15-pin, female) for the following input signals

Input signal	Maximum cable length	Maximum input frequency
11 μ App	30 m	100 kHz
1 Vpp	60 m	500 kHz
EnDat 2.1/2.2	100 m	-

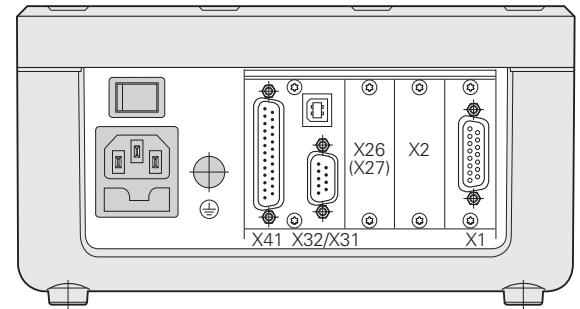

Fig. II.5 Connections



Pin assignment X1/X2

D-sub connector 15-pin	Input signal 11 μ App	Input signal 1 Vpp	EnDat 2.1/2.2
1	I1+	A+	
2	0 V (UN)	0 V (UN)	0 V (UN)
3	I2+	B+	
4	5 V (Up)	5 V (Up)	5 V (Up)
5			Data
6	Internal shield		
7	I0-	R-	
8			Clock
9	I1-	A-	
10		0 V sensor	0 V sensor
11	I2-	B-	
12		5 V sensor	5 V sensor
13			Data (inverse)
14	I0+	R+	
15			Clock (inverse)
Housing	External shield	External shield	External shield



In the INSTALLATION SETUP menu, you define the parameters for the encoder (see "Setting up the encoder" on page 72).

Optional: Analog module with ± 10 -V interface at input X1 or X2 for connecting an analog sensor

For example, you can connect an **analog linear encoder** to this connection, or a temperature sensor with a voltage interface to X2. The ND converts the voltage value to a readable measured value.

A separate description of the analog module is included with the module.

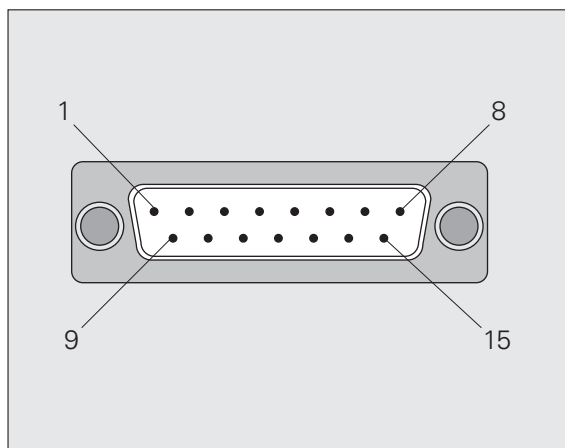

Fig. II.6 15-pin encoder connector X1 or X2 for the encoder input on the rear panel



II – 2 Installation Setup

INSTALLATION SETUP menu

The ND 287 offers two categories for setting up operating parameters: JOB SETUP and INSTALLATION SETUP.

- The JOB SETUP parameters are used to accommodate specific machining requirements for each job, see "Job Setup" on page 30.
- The INSTALLATION SETUP menu is used to establish encoder, display and communication parameters.

To call the INSTALLATION SETUP menu:

- ▶ Begin by pressing the SETUP soft key. This opens the JOB SETUP menu.
- ▶ Press the INSTALLATION SETUP soft key.
- ▶ Use the numeric keys to enter the correct passcode (**95148**) and then press ENTER.

INSTALLATION SETUP parameters are established during the initial installation and, most likely, will not often change. For this reason, the INSTALLATION SETUP parameters are protected by a **passcode**.



Once you enter the passcode, it will not have to be entered again until you cycle power.

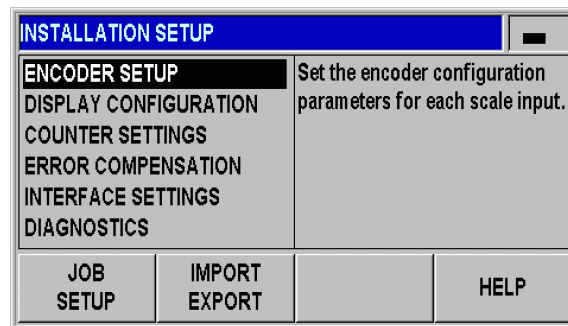

Fig. II.7 INSTALLATION SETUP menu



When in the INSTALLATION SETUP menu, the following soft keys will be available (see Fig. II.7):

- **JOB SETUP**
Press to begin accessing the JOB SETUP parameters (see "Job Setup" on page 30).
- **IMPORT/EXPORT**
Press this soft key to call the IMPORT or EXPORT soft keys for transmitting the operating parameters (see "Serial data transfer with the Import or Export function" on page 102).
- **HELP**
This soft key will open on-line help.

Press the NAVIGATION key to move through the pages of menu parameters. To view and change menu parameters, use the UP/DOWN arrow key to highlight the parameter of interest and press the ENTER key.

On the following pages you will find more information on the menu parameters.



Setting up the encoder

In the ENCODER SETUP form you configure the ND 287 for the connected encoder:

- ▶ The cursor will default to the ENCODER SETUP field upon opening Installation Setup. Press the ENTER key to confirm your selection.
- ▶ If you have configured the ND for two axes in the APPLICATION field under COUNTER SETTINGS, a list of of the two possible encoder inputs, labelled INPUT X1 and X2, appears.
- ▶ Scroll to the input you want to configure and press ENTER.
- ▶ The cursor will be in the ENCODER TYPE field. Select the encoder type by pressing the TYPE soft key:
 - LINEAR: Linear encoder
 - ROTARY: Rotary encoder
 - COMPENSATION: If an analog module (option) with a temperature sensor is connected to input X2, and a linear encoder to input X1, the COMPENSATION parameter is available for defining temperature-dependent axis-error compensation.
 - SENSOR: For inputs with analog module (option) and connected analog sensor
- ▶ Press the ENTER key to confirm your selection.
- ▶ The ND automatically enters the measurement signal received in the ENCODER SIGNAL field: NO SIGNAL, 1 VPP, 11 μ App, EnDat 2.1, ENDAT 2.2 or ANALOG.

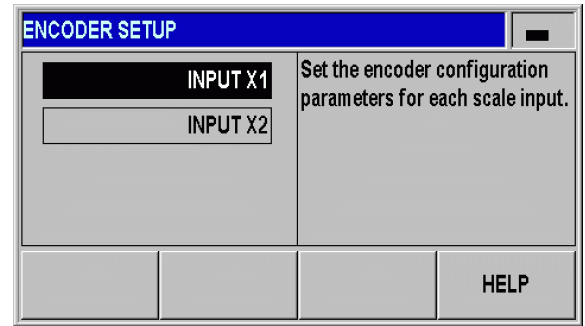

Fig. II.8 Encoder setup form

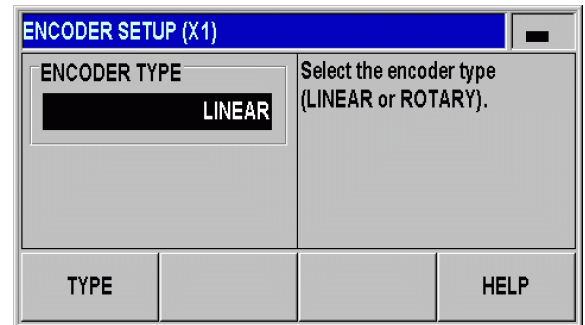



Fig. II.9 Encoder type



Incremental linear encoder

- ▶ For linear encoders, cursor to the SIGNAL PERIOD field and toggle the COARSER or FINER soft key to select a predefined encoder signal period, or type in the exact signal period (in μm) desired (see "Encoder Parameters" on page 99).
- ▶ In the REFERENCE MARK field, toggle the REF MARK soft key to select whether the encoder has no reference signal (NONE), a single reference mark (SINGLE) or distance-coded reference marks (CODED/...). For **distance-coded** reference marks, select the spacing (500, 1000, 2000 or 5000 signal periods).
- ▶ In the EXTERNAL REF field, press the ON/OFF soft key to select whether **pin 25 at connection X41** is active or inactive. This pin can be used to activate or deactivate the reference mode. The respective current status is changed.
- ▶ In the COUNT DIRECTION field, select the count direction by pressing the POSITIVE/ NEGATIVE soft key. If the encoder's count direction matches the user's traverse direction, select POSITIVE. If the directions do not match, select NEGATIVE.
- ▶ In the ERROR MONITOR field, select whether the ND will monitor and display encoder counting and signal errors by pressing the ERROR soft key. In the ERROR MONITOR field, you can select OFF, FREQUENCY, CONTAMINATION or FRQ.+CONTAMINATION. When an error message occurs, press the C key to acknowledge it.

 If you set the ERROR MONITOR field to OFF, the ND 287 will ignore encoder errors.

Counting errors are caused by contamination or excessive frequency:

- **Contamination:** The signal to the encoder falls below a set limit.
- **Frequency errors:** The signal frequency exceeds the set limit.

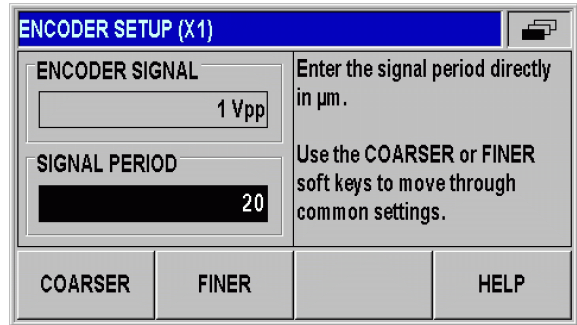

Fig. II.10 Incremental linear encoder form

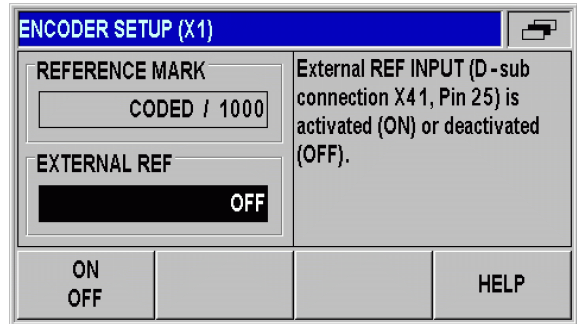

Fig. II.11 Incremental linear encoder form

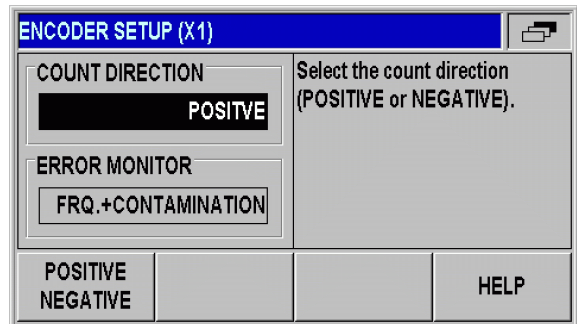

Fig. II.12 Incremental linear encoder form



Incremental angle encoder

- ▶ For rotary encoders, enter the encoder's signal period per revolution (360°) directly in the SIGNAL PERIOD field (see "Encoder Parameters" on page 99). Press the DOWN arrow key to move to the next parameter.
- ▶ In the REFERENCE MARK field, use the numeric keys to enter the number of reference marks (0 for NONE, 1 for SINGLE, ...) per revolution (360°).
- ▶ In the EXTERNAL REF field, press the ON/OFF soft key to select whether **pin 25 at connection X41** is active or inactive. This pin can be used to activate or deactivate the reference mode. The respective current status is changed.
- ▶ In the COUNT DIRECTION field, select the count direction by pressing the POSITIVE/ NEGATIVE soft key. If the encoder's count direction matches the user's traverse direction, select POSITIVE. If the directions do not match, select NEGATIVE.
- ▶ In the ERROR MONITOR field, select whether the ND will monitor and display encoder counting and signal errors by pressing the ERROR soft key. In the ERROR MONITOR field, you can select OFF, FREQUENCY, CONTAMINATION or FRQ.+CONTAMINATION. When an error message occurs, press the C key to acknowledge it.



If you set the ERROR MONITOR field to OFF, the ND 287 will ignore encoder errors.

Counting errors are caused by contamination or excessive frequency:

- **Contamination:** The signal to the encoder falls below a set limit.
- **Frequency errors:** The signal frequency exceeds the set limit.

The screenshot shows the 'ENCODER SETUP (X1)' screen. The 'ENCODER SIGNAL' field is set to '1 Vpp'. The 'SIGNAL PERIOD' field is set to '2048'. A text box on the right says 'Enter the signal period directly (signal period per revolution)'. At the bottom right is a 'HELP' button.

Fig. II.13 Incremental angle encoder form

The screenshot shows the 'ENCODER SETUP (X1)' screen. The 'NUMBER REF. MARKS' field is set to '8'. The 'EXTERNAL REF' field is set to 'ON'. A text box on the right says 'Enter the number of reference marks per revolution (360°). (The value zero means no reference mark.)'. At the bottom right is a 'HELP' button.

Fig. II.14 Incremental angle encoder form

The screenshot shows the 'ENCODER SETUP (X1)' screen. The 'COUNT DIRECTION' field is set to 'POSITIVE'. The 'ERROR MONITOR' field is set to 'FRQ.+CONTAMINATION'. A text box on the right says 'Select the count direction (POSITIVE or NEGATIVE)'. At the bottom left are 'POSITIVE' and 'NEGATIVE' buttons, and at the bottom right is a 'HELP' button.

Fig. II.15 Incremental angle encoder form



Absolute encoder



For **absolute** encoders with EnDat 2.1/2.2 interface, you can only define the **COUNT DIRECTION** and the **ERROR MONITOR**.

All other fields in the ENCODER SETUP form show information that has been transferred from the encoder.

Press the ENDAT ENC. FILE soft key to display the encoder's electronic **ID label**. In this form, you can cancel an **existing datum shift** by pressing the CANCEL DATUM SHIFT soft key.

When an EnDat 2.1 interface is used, the resolution is limited, because the incremental signals are ignored.

ENCODER SETUP (X2)			
COUNT DIRECTION		Select the count direction (POSITIVE or NEGATIVE).	
POSITIVE			
ERROR MONITOR			
FRQ.+CONTAMINATION			
POSITIVE		ENDAT ENC. FILE	HELP
NEGATIVE			

Fig. II.16 Absolute encoder form



Analog sensor with ±10 V interface, preferably a temperature sensor

- ▶ In the COUNT DIRECTION field, select the count direction by pressing the POSITIVE/ NEGATIVE soft key. If the encoder's count direction matches the user's traverse direction, select POSITIVE. If the directions do not match, select NEGATIVE.
- ▶ In the four following fields, enter any two voltage/measured-value pairs for the correct definition of the analog sensor: At first, enter the values in the VOLTAGE 1 and MEASURED VALUE 1 fields, and then in the VOLTAGE 2 and MEASURED VALUE 2 fields. The ND 287 uses the values to calculate a linear relationship between input voltage and measured value in the range from -10 V to +10 V. To ensure the highest possible measuring accuracy, enter the voltage values with an accuracy of 5 mV.
- ▶ If you have selected COMPENSATION for INPUT X2 in the ENCODER TYPE field in the ENCODER SETUP menu, two further parameters for defining temperature-dependent axis-error compensation are displayed.
- ▶ In the COEF. OF EXPANSION field, enter a value for the coefficient of expansion **E** in $\mu\text{m}/\text{mK}$.
- ▶ In the REF. TEMPERATURE field, enter the temperature T_R to be deducted from the measured temperature.
- ▶ The axis-error compensation is calculated according to the following formula:

$$L_{1} = L_{0} * (1 + E * (T - T_{R}))$$
 - L_{1} : Compensated linear value of the encoder at input X1 after axis-error compensation
 - L_{0} : Displayed linear value of the encoder at input X1 without compensation
 - E: Coefficient of expansion in $\mu\text{m}/\text{mK}$
 - T: Temperature measured in $^{\circ}\text{C}$
 - T_R : Defined reference temperature in $^{\circ}\text{C}$
- ▶ Press ENTER to confirm your entry.
- ▶ The ND 287 constantly displays the measured temperature on the left side of the message line.

The screenshot shows the 'ENCODER SETUP (X2)' menu. The 'ENCODER SIGNAL' is set to 'ANALOG'. The 'COUNT DIRECTION' is set to 'POSITIVE'. A text box on the right says 'Select the count direction (POSITIVE or NEGATIVE)'. At the bottom, there are buttons for 'POSITIVE', 'NEGATIVE', and 'HELP'.

Fig. II.17 Analog sensor form

The screenshot shows the 'ENCODER SETUP (X2)' menu. The 'VOLTAGE 1 [VOLT]' field contains '-3.548' and the 'MEASURED VALUE 1' field contains '-13.458'. A text box on the right says 'Enter the voltage for the first value pair in V.'. At the bottom, there is a 'HELP' button.

Fig. II.18 Analog sensor form

The screenshot shows the 'ENCODER SETUP (X2)' menu. The 'COEF. OF EXPANSION' field contains '8.7' and the 'REF. TEMPERATURE' field contains '20.0'. A text box on the right says 'Enter the coefficient of thermal expansion in $\mu\text{m}/\text{mK}$ '. At the bottom, there is a 'HELP' button.

Fig. II.19 Temperature sensor form



Configuring the display

In the DISPLAY CONFIGURATION form you determine the display resolution for the different encoders.

- ▶ In the INSTALLATION SETUP menu, select DISPLAY CONFIGURATION.
- ▶ If you have configured the ND for two axes in the APPLICATION field under COUNTER SETTINGS, a list of the two possible encoder inputs, labelled INPUT X1 and X2, appears.
- ▶ Scroll to the input you want to configure and press ENTER.



The selectable display resolution depends on the signal period. The smallest selectable display resolution corresponds to the rounded-off value calculated from dividing the signal period by 4096. For linear encoders, resolutions from 0.5 mm to 0.001 μm are possible, and for rotary encoders from 0.5° to 0.000001° (00°00'00.1").

Linear encoder

- ▶ Press the COARSER or FINER soft key to select the display resolution for the axis display in the DISPL. RESOLUTION X1 or X2 field.

Angle encoder

- ▶ Press the COARSER or FINER soft key to select the display resolution for the axis display in the DISPL. RESOLUTION X1 or X2 field.
- ▶ In the ANGLE DISPLAY field, press the ANGLE soft key to choose between the three following angle formats:
 - +/- 180 DEGREES
 - 360 DEGREES
 - +/- INFINITE

Analog sensor for compensation

- ▶ Press the COARSER or FINER soft key to select the display resolution for the measured value in the DISPL. RESOLUTION X1 or X2 field. The minimum resolution depends on the assignment of the measured values to the voltage values. The ND subdivides the input voltage range of $\pm 10\text{ V}$ 4096-fold, i.e. in steps of 5 mV.



If two axes are coupled, the finer of the two display resolutions will be used.

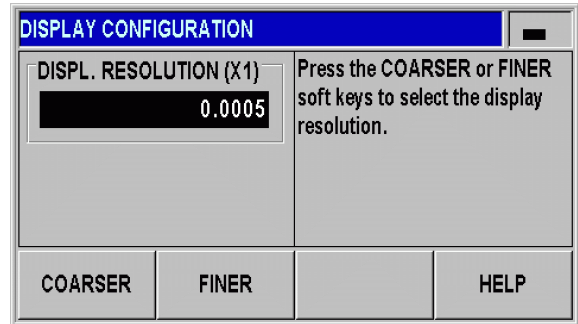

Fig. II.20 DISPLAY CONFIGURATION form for linear encoder

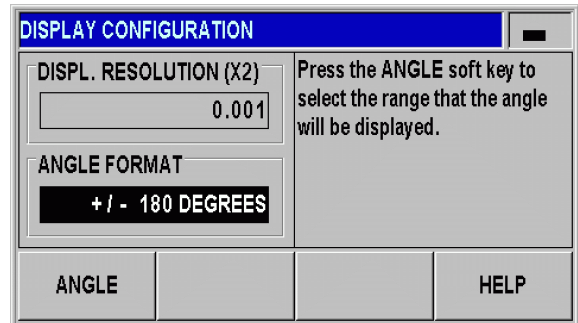

Fig. II.21 DISPLAY CONFIGURATION form for rotary encoder

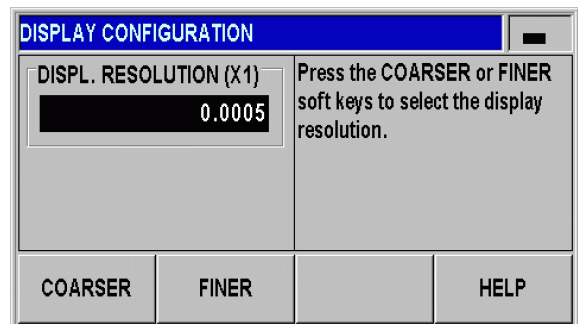

Fig. II.22 DISPLAY CONFIGURATION form for analog sensor



Counter settings

In the COUNTER SETTINGS form, you define the user application for the position display unit (see Fig. II.23):

- ▶ In the INSTALLATION SETUP menu, select COUNTER SETTINGS.
- ▶ In the APPLICATION field, press the 1 AXIS/2 AXES soft key to select the inputs you want to activate:
 - If the position display unit is configured for 1 AXIS, then only input X1 is active.
 - If the position display unit is configured for 2 AXES, inputs X1 and X2 are active. The ND can display the axis values separately, or as a coupled position value. If you select 2 AXES, the FUNCTION F(X1,X2) soft key appears. Press this soft key to enter a formula for the coupled position display (see "Formula for coupled position" on page 79).
- ▶ In the KEYBOARD field, use the KEYPAD soft key to release/lock the keypad. To release the locked keypad, press and hold the NAVIGATION key for at least **three seconds**. Then enter the password (**246584**) for releasing the keypad and confirm your entry by pressing the ENTER key, or cancel by pressing the C key.
- ▶ Press the DOWN arrow key to move to the next parameter.
- ▶ Press the SECOND DEC. POINT soft key to display a second decimal point after 1/1000 inches (mm).
- ▶ Press the POWER UP SCREEN soft key to define whether the ND displays the initial screen after it has been switched on.
- ▶ Press the DOWN arrow key to move to the next parameter.
- ▶ The DISPLAY UNIT field shows the **type** of position display.
- ▶ The SOFTWARE VERSION field shows the **currently installed software version** and its **identification number**. To update your software version, see "Software update (firmware update) installation" on page 104.
- ▶ The FACTORY DEFAULTS soft key resets the configuration parameters to factory defaults. Press the ENTER key to confirm, or press the C key to cancel.



When a temperature sensor at input X2 is used, the ND compensates the axis error (see "Analog sensor with ± 10 V interface, preferably a temperature sensor" on page 76).

COUNTER SETTINGS			
APPLICATION	2 AXES	Select 1-axis display (linear/rotary) or 2-axis display (sum/difference).	
KEYBOARD	RELEASE KEYPAD	Lock or release the keypad.	
KEYPAD		FUNCTION f(X1,X2)	HELP

Fig. II.23 COUNTER SETTINGS form

COUNTER SETTINGS			
SECOND DEC. POINT	ON	Select LCD screen content after switching on the position display unit.	
POWER UP SCREEN	OFF		
POWER UP SCREEN			HELP

Fig. II.24 COUNTER SETTINGS form

COUNTER SETTINGS			
DISPLAY UNIT	ND-287	Press FACTORY DEFAULTS to reset all parameters to their factor default settings.	
SOFTWARE VERSION	V1.02 ID 646118-02		
FACTORY DEFAULTS			HELP

Fig. II.25 COUNTER SETTINGS form



Formula for coupled position

In this form, you can enter a formula for coupling the two axes. The following mathematical operations, symbols and variables are available:

- Basic arithmetic: Addition, subtraction, multiplication and division
- Parentheses
- Trigonometric functions: Sine, cosine, tangent, arc sine, arc cosine and arc tangent
- Circle constant pi
- Axis variables X1 and X2
- ▶ Enter the desired formula.
- ▶ If you want to delete a character you have entered, press the DOWN arrow key.
- ▶ After you have confirmed your entries by pressing ENTER, the ND 287 checks the formula for syntax errors, and displays an error message if the formula is not correct.



- The ND 287 checks whether all required operators (e.g. 3X1 must be entered as 3*X1) have been entered, and whether opening parentheses are followed by **closing parentheses**.
- Axis values that are used as divisors may cause a **division-by-zero** or display-overflow problem. The ND 287 prevents these errors by displaying the **Display overflow** message. After you have removed the affected axis from the range about zero, the ND 287 will display a correct numerical value again.
- The ND 287 cannot check whether the entered formula is going to produce a **meaningful result** for you. It is your responsibility to check this.

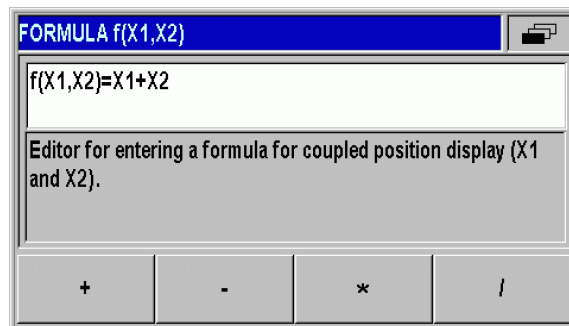

Fig. II.26 Formula input form

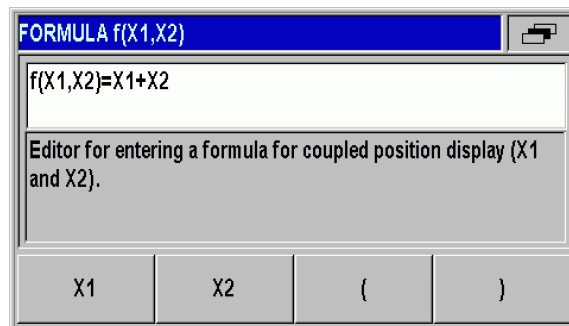

Fig. II.27 Formula input form



Error compensation

The distance a cutting tool travels, measured by an encoder, can in certain cases, differ from the actual tool travel. This error can occur due to ball screw pitch error or deflection and tilting of axes.

This error can either be **linear** or **non-linear**. You can determine these errors with a reference measurement system, e.g. the **VM 101** from HEIDENHAIN. From an analysis of the error it can be determined which form of compensation is required (linear or non-linear).

The ND 287 can compensate these errors. Each axis can be programmed separately with the appropriate compensation.

The ND can also compensate errors caused by **temperature influences**. A linear encoder must be connected to input X1, and an analog module (option) with a temperature sensor must be connected to input X2.



Only non-linear **error compensation** is available when using **rotary encoders**.



Linear error compensation (not for rotary encoders)

Linear error compensation can be applied if the results of the comparison with a reference standard show a linear deviation over the whole measuring length. In this case the ND 287 can compensate the error mathematically by calculating the **LEC correction factor**.

To calculate the linear correction factor, use the following formula:

$$LEC = \left(\frac{S - M}{M} \right) \times 10^6 \text{ ppm}$$

S: length measured with reference standard

M: measured length with device at axis

ppm: parts per million

1 ppm = 10⁻⁶ = 1 μm/m = 1 μinch/inch

Example:

If the length of the standard you used is 500 mm and the measured length along the X axis is 499.95 mm, then the LEC for the X axis is 100 ppm:

$$LEC = \left(\frac{500 - (499,95)}{499,95} \right) \times 10^6 \text{ ppm} = 100 \text{ ppm}$$

Entering linear error compensation

- ▶ In the INSTALLATION SETUP menu, select ERROR COMPENSATION.
- ▶ If you have configured the ND for two axes in the APPLICATION field under COUNTER SETTINGS, you can define error compensation for the two possible encoder inputs, labelled INPUT X1 and X2.
- ▶ Select the input you want to define.
- ▶ Press the ERROR COMP. soft key to select the desired type of compensation.
 - If you select OFF, no error compensation will be applied.
 - 0.0 PPM: Use the numerical keys to enter the **linear** correction factor in **ppm**.
 - NONLINEAR (see "Non-linear error compensation" on page 82).
- ▶ If necessary, press the UP or DOWN arrow key to select the next input, and define the error compensation for this input.
- ▶ Press ENTER to confirm your entries.

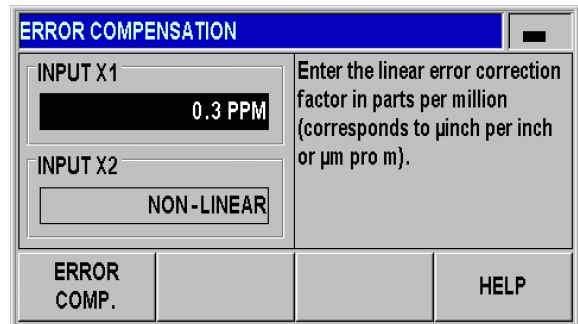

Fig. II.28 Linear error compensation form



Non-linear error compensation



- Non-linear error compensation is available for **encoders with reference marks**, for **absolute** encoders and for **analog** sensors.
- If non-linear error compensation has been defined, no error compensation will be applied until the **reference marks** have been crossed.

Non-linear error compensation should be applied if the results of the comparison with a reference standard show an alternating or oscillating deviation. The ND 287 supports up to **200 correction points per axis**. The error value between two entered adjacent correction points is calculated with linear interpolation. The required correction values must be calculated and entered in an error compensation table.

For **rotary encoders, 180 correction points spaced every 2°** are predefined by the ND 287.

Selecting non-linear error compensation

- ▶ In the INSTALLATION SETUP menu, select ERROR COMPENSATION.
- ▶ If you have configured the ND for two axes in the APPLICATION field under COUNTER SETTINGS, you can define error compensation for the two possible encoder inputs, labelled INPUT X1 and X2.
- ▶ Select the input you want to define.
- ▶ Press the ERROR COMP. soft key to select NON-LINEAR.

ERROR COMPENSATION			
INPUT X1	0.3 PPM	Press EDIT TABLE to create a new error compensation table, or to view or edit the current table for this input.	
INPUT X2	NON-LINEAR		
ERROR COMP.	EDIT TABLE		HELP

Fig. II.29 Non-linear error compensation form



Creating an error compensation table

- ▶ To start a new error compensation table, first press the EDIT TABLE soft key. This opens the ERROR COMPENSATION TABLE form.
- ▶ It may occur that the error is not caused by the axis to be compensated. Press the X1/X2 soft key to select the appropriate axis in the ERROR-CAUSING AXIS field.
- ▶ All correction points (up to 200) are equally spaced from the start point. Enter the distance between each of the correction points. Select POINT SPACING and press the SPACING soft key or the ENTER key. Enter a value and press ENTER.
- ▶ Enter the START point:
 - If the start point is known, enter the start point. Select START POINT and press the START POINT soft key or the ENTER key. The start point is measured from the scale's reference point.
 - If the start point is **not** known, move to the location of the start point. Please keep in mind that the reference marks must have been crossed. Press the TEACH POSITION soft key. Press the ENTER key to confirm the position.
- ▶ In the REF DISPLAY field, the ND shows the **current value of the axis to be compensated** without considering the datums entered.

 After a new start point has been entered, the ND 287 will adjust the previous values in the error compensation table.

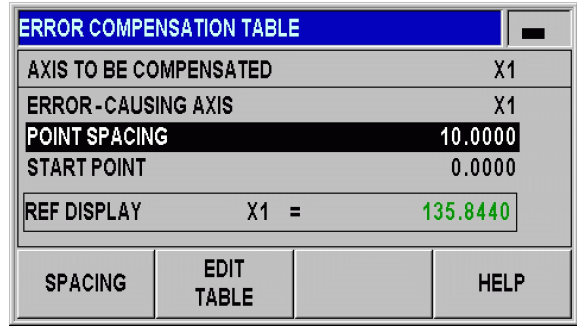

Fig. II.30 Error compensation table

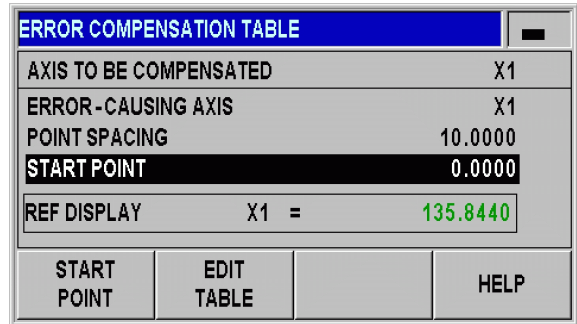

Fig. II.31 Error compensation table

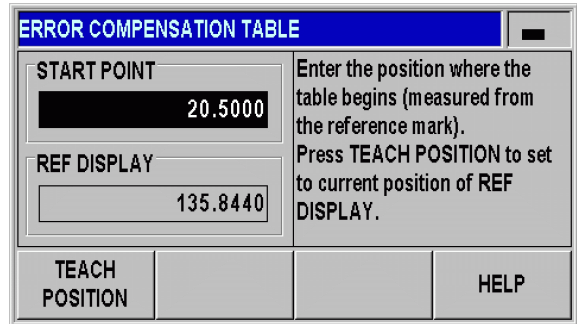

Fig. II.32 Error compensation table: Enter the START point.



Configuring an error compensation table

- ▶ Press the EDIT TABLE soft key to view the table entries.
- ▶ Use the UP or DOWN ARROW keys or the numeric keys to move the cursor to the correction point to be added or changed. Press ENTER to confirm your selection.
- ▶ Enter the known error which exists at this point. Confirm with the ENTER key.
- ▶ When completed, press the C key to exit the table and return to the ERROR COMPENSATION form.

Reading the graph

The ND 287 can display the error compensation table in table or graphical format. The graph shows a plot of a translation error vs. measured value. The graph has a fixed scale.

Viewing the error compensation table

- ▶ Press the EDIT TABLE soft key.
- ▶ Press the UP or DOWN arrow key or the numeric keys to move the cursor within the table.
- ▶ To switch between the table and graph views, press the VIEW soft key.
- ▶ Use the ZOOM IN or ZOOM OUT soft key to enlarge or reduce to graphic to 20 and 200 points, respectively. The enlarged graphic display can be scrolled forward or backward by 20 points by pressing the ← and ⇒ soft key.

ERROR COMPENSATION TABLE			
NO.	MEASURED VALUE	X2	ERROR X2
000	20.0000		0.0000
001	30.0000		0.0500
002	40.0000		0.0800
003	50.0000		-0.0400
004	60.0000		0.1000

VIEW	CLEAR TABLE	IMPORT EXPORT	HELP
------	-------------	---------------	------

Fig. II.33 Editing an error compensation table

ERROR COMPENSATION TABLE	
<p>MEASURED VALUE</p> <input style="width: 100%;" type="text" value="60.0000"/>	<p>Enter the amount of error which exists at the measured position.</p>
<p>ERROR</p> <input style="width: 100%;" type="text" value="0.1000"/>	<p>The ERROR field may be left blank.</p>
HELP	

Fig. II.34 Entering the error determined for the measured value

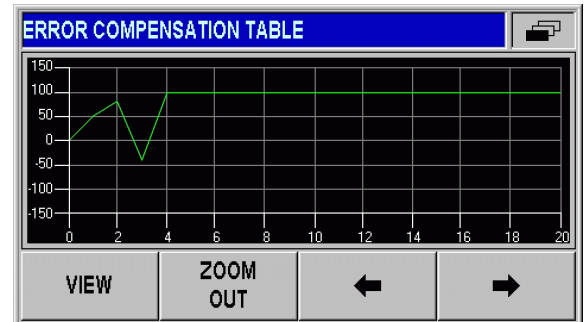

Fig. II.35 Graphic representation of compensation values



The error compensation table data may be saved to or loaded from a PC via the serial port (see "Setting up the serial port" on page 86).

Exporting the current compensation table

- ▶ Press the EDIT TABLE soft key.
- ▶ Press the IMPORT/EXPORT soft key.
- ▶ Press the EXPORT TABLE soft key.

Importing a new error compensation table

- ▶ Press the EDIT TABLE soft key.
- ▶ Press the IMPORT/EXPORT soft key.
- ▶ Press the IMPORT TABLE soft key.
- ▶ Press the IMPORT READY soft key.

ERROR COMPENSATION TABLE			
NO.	MEASURED VALUE	X2	ERROR X2
000	20.0000		0.0000
001	30.0000		0.0500
002	40.0000		0.0800
003	50.0000		-0.0400
004	60.0000		0.1000
IMPORT TABLE	EXPORT TABLE		

Fig. II.36 Importing or exporting compensation values

ERROR COMPENSATION TABLE			
NO.	MEASURED VALUE	X2	ERROR X2
000	20.0000		0.0000
001	30.0000		0.0500
002	40.0000		0.0800
003	50.0000		-0.0400
004	60.0000		0.1000
IMPORT READY			

Fig. II.37 Importing compensation values



Setting up the serial port

The ND 287 features two serial interfaces: **RS-232-C/V.24 (X31)** and **USB (UART, X32)**.



Danger of electrical shock!

The interfaces X31 and X32 comply with the requirements of EN 50 178 for **low voltage electrical separation**.

Do not engage or disengage any connections while the unit is under power.

A printer or computer with a serial data interface may be connected to the available serial ports in order to perform the following tasks:

- Sending measured values, error compensation tables or configuration files to a printer or computer.
- Receiving error compensation tables or configuration files from a computer.
- In addition, the interfaces allow external operation of the ND 287.

As an option, an Ethernet module (100baseT) can be connected to X26/X27 so that an Ethernet interface is available.

Setting up the data interface

- ▶ In the INSTALLATION SETUP menu, select INTERFACE SETTINGS.
- ▶ In the SERIAL PORT field, use the USB/RS-232 soft key to select the interface you want to use.
- ▶ The BAUD RATE field can be set to 110, 150, 300, 600, 1200, 2400, 9600, 19200, 38400, 57600 or 115200 by using the DECREASE or INCREASE soft keys.

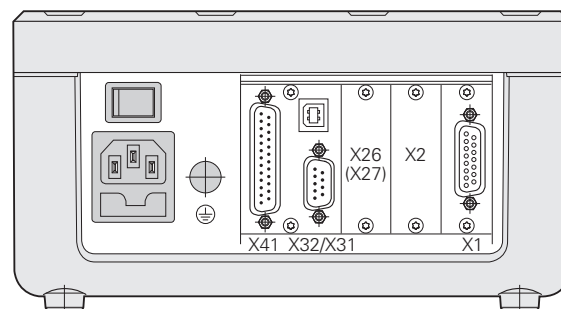

Fig. II.38 Connections

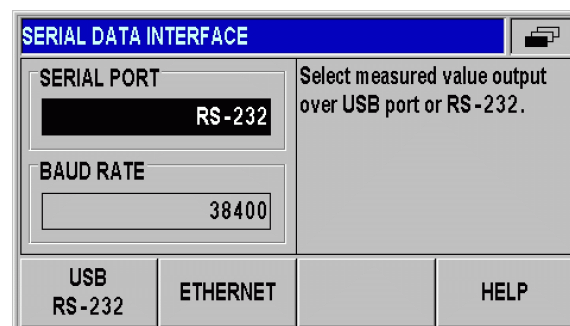

Fig. II.39 RS-232-C/V.24 data interface

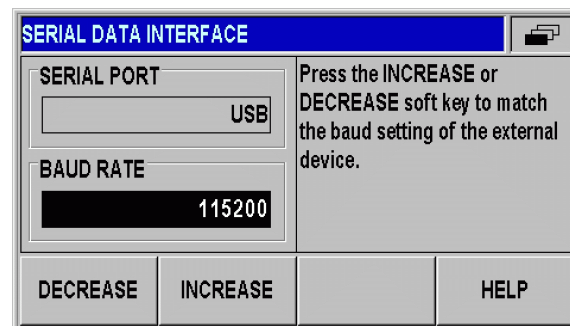

Fig. II.40 USB (UART) data interface



- ▶ Press the 7/8 soft key to set the DATA BITS field to 7 or 8.
- ▶ Press the 1/2 soft key to set the STOP BITS field to 1 or 2:
- ▶ The PARITY field can be set to NONE, EVEN or ODD using the soft keys provided.
- ▶ OUTPUT TAIL is the number of carriage returns that will be sent at the end of the transmission. The output tail is initially 0 and can be set to a positive integer value between 0 and 99 by using the numerical keys.



There is no parameter to enable or disable the serial ports. Data will only be sent to the serial port if the **external device is ready**.

For information about the cable connection, pin assignment, data input/output and external operation, see "Data Interface" on page 101.

The serial port settings will be retained on a power cycle.



Data is transferred in the following sequence: Start bit, data bits, parity bit, stop bits.

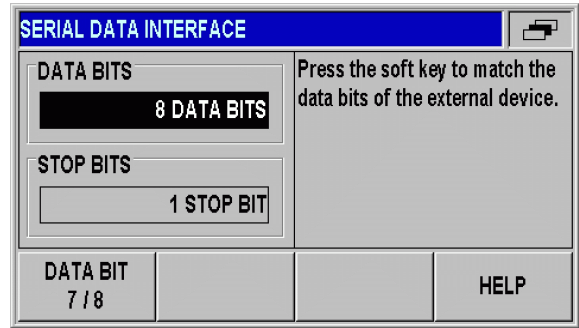

Fig. II.41 Data interface: Parameter input

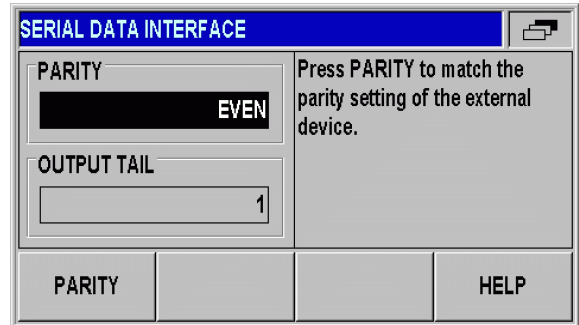

Fig. II.42 Data interface: Parameter input



Diagnostics

The DIAGNOSTICS submenu provides parameters for testing the keypad, the LCD display, the connected encoders, the supply voltages, and the function of the switching inputs/outputs (see Fig. II.43):

- ▶ In the INSTALLATION SETUP menu, select DIAGNOSTICS.
- ▶ Select the desired test. The tests are described in the following sections.

Keypad test

An image of the keypad of the ND287 provides an indication when a key is pressed and released.

- ▶ Press each hard and soft key to test. A **dot** will appear on each key when it has been pressed indicating that it is operating properly.
- ▶ Press the C hard key twice to exit the keypad test.

Display test

LCD display test:

- ▶ To test the LCD display, press the ENTER key **four times** to set the LCD display to black with white inside, white with black inside, red-green-blue and back to normal.

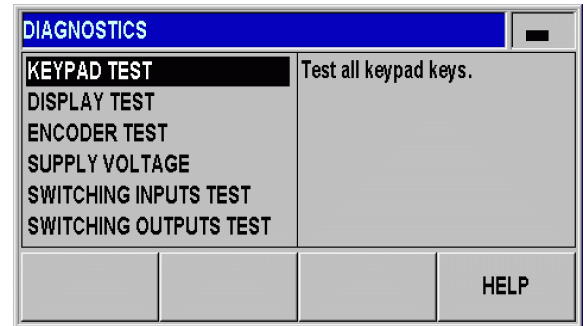

Fig. II.43 Diagnostics menu

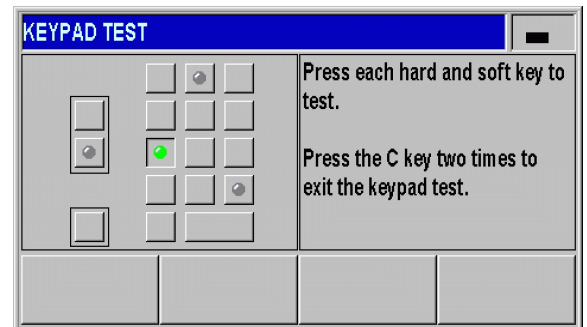

Fig. II.44 Keypad test

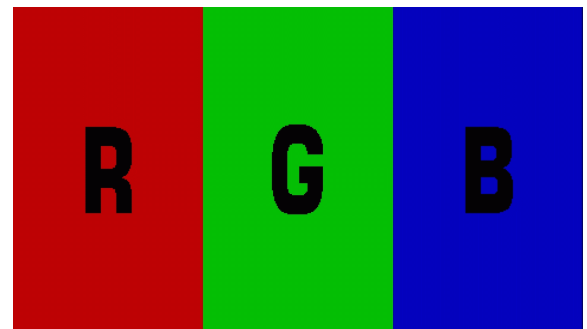

Fig. II.45 Display test

Encoder test

Use this test to check the signals of the 11 μ App or 1 Vpp interface, the EnDat 2.1/2.2 interface or the voltage at the analog module.

- ▶ If you have configured the ND for two axes in the APPLICATION field under COUNTER SETTINGS, you can perform the test for the two possible encoder inputs.
- ▶ Select input X1 or X2 and press ENTER.

Encoders with 11 μ App or 1 Vpp interface:

- ▶ As the encoder is moved, you will see the signals of the A and B channels as Lissajous figure (see Fig. II.46), as well as the amplitude, symmetry and phase offset values.

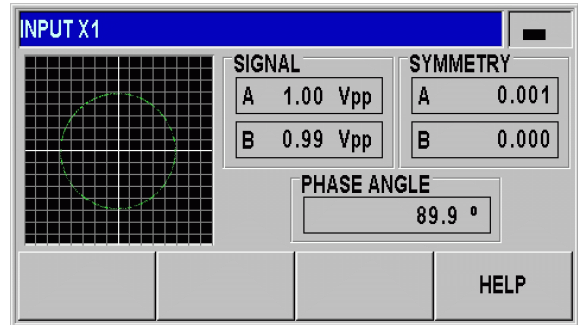

Fig. II.46 Encoder test: 1 Vpp interface

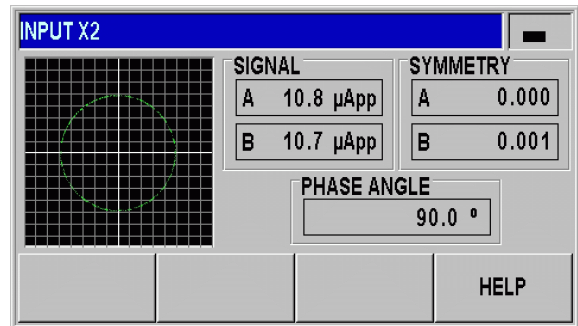

Fig. II.47 Encoder test: 11 μ App interface



Encoders with EnDat 2.1/2.2 interface:

- ▶ The form displays the electronic ID label of the connected encoder: Transmission format, signal periods, measuring steps, distinguishable revolutions, ID number and serial number.
- ▶ Only for encoders with EnDat 2.2 interface: The DIAGNOSIS soft key opens a form showing the function reserve of the encoder:
 - Incremental track (INC)
 - Absolute track (ABS)
 - Position value calculation
- ▶ Press the ALARMS soft key to display the alarms that are supported by the connected encoder, and to show whether errors have occurred. A color-filled square before the respective alarm indicates the status:
 - **Gray** means that the alarm is **not** supported by the connected encoder.
 - **Green** means that the alarm is supported by the connected encoder, and **no error** has occurred yet.
 - **Red** signalizes that an error has occurred.
- ▶ Press the WARNINGS soft key to display the warnings that are supported by the connected encoder, and to check whether warnings have occurred. A color-filled square before the respective warning indicates the status:
 - **Gray** means that the warning is **not** supported by the connected encoder.
 - **Green** means that the warning is supported by the connected encoder, and **no warning** has occurred yet.
 - **Red** signalizes that a warning has occurred.
- ▶ To clear alarms or warnings that have occurred, press the RESET soft key when the ALARMS or WARNINGS window is open.

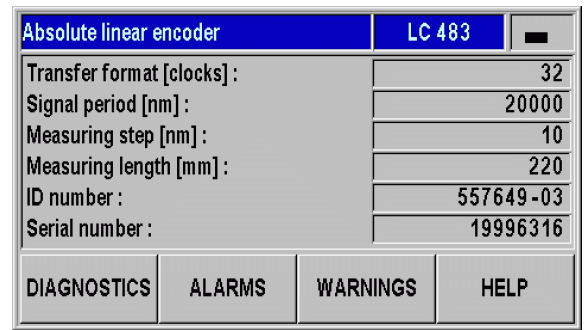

Fig. II.48 Encoder test:
EnDat 2.1/2.2 interface

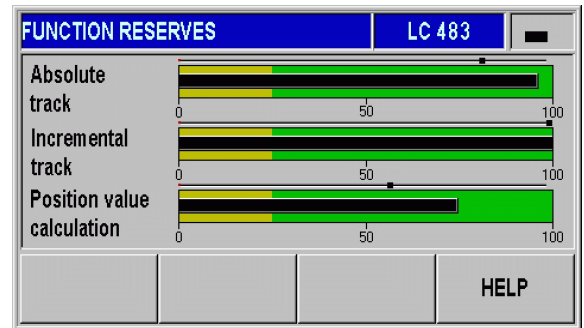

Fig. II.49 Encoder test:
EnDat 2.2 interface

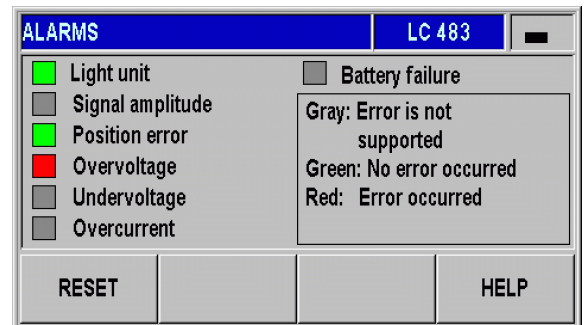

Fig. II.50 Encoder test:
EnDat 2.1/2.2 interface



Analog sensors with ± 10 V interface:

- ▶ In the form, the voltage at the input of the analog module is displayed as a numerical value and in a bar graph.

Power supply

Check the supply voltage at encoder inputs X1 and X2 (optional). It should normally be slightly above 5 V in order to ensure that the voltage level at the encoder input complies with the specification (5 V \pm 5%) even at greater cable lengths.

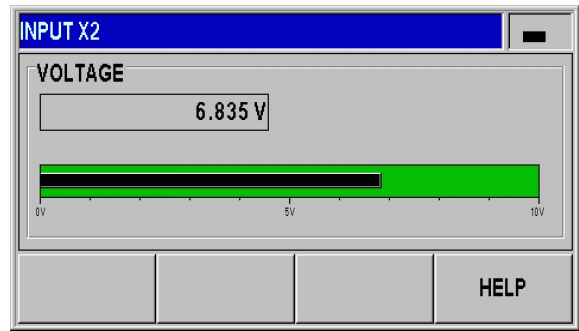

Fig. II.51 Encoder test: Analog sensor

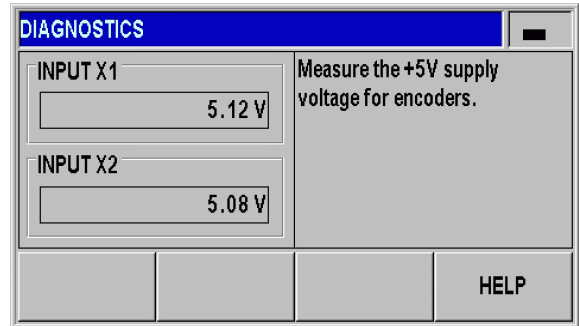

Fig. II.52 Power supply



Switching inputs test



Danger to internal components!

- The power supply of external circuits must comply with **EN 50178 requirements for low voltage electrical separation.**
- Connect inductive loads only with a **quenching diode parallel to the inductance.**



Danger to internal components!

Use only shielded cables and **connect the shield to the connector housing.**

The ND displays a list with all switching inputs at the D-sub connection X41 (see "Switching inputs at D-sub connection X41" on page 94). The pins are listed together with their designations, a gray/green dot and their current states (HIGH or LOW). The **function of the inputs at connection X41** can be tested:

- ▶ As soon as a pin has been activated (=LOW), the gray dot next to the respective pin designation becomes green and the status changes to LOW if the input functions correctly.

SWITCHING INPUTS TEST			
Pin 2	● = HIGH	Pin 7	● = HIGH
Pin 3	● = LOW	Pin 8	● = HIGH
Pin 5	● = HIGH	Pin 9	● = HIGH
Pin 6	● = HIGH	Pin 25	● = LOW
Pin 22 or Pin 23		● = HIGH	
Pin 12, 13 : Do not assign			
			Inputs at D-sub connection EXT (X41) (active low)
			HELP

Fig. II.53 Switching inputs test



Switching outputs test



Danger to internal components!

- The power supply of external circuits must comply with **EN 50178 requirements for low voltage electrical separation.**
- Connect inductive loads only with a **quenching diode parallel to the inductance.**



Danger to internal components!

Use only shielded cables and **connect the shield to the connector housing.**

The ND 287 displays all **switching outputs at connection X41** together with their designations, a gray/green dot and their current states (HIGH or LOW; see "Switching outputs at D-sub connection X41" on page 96). To start the switching outputs test:

- ▶ Press the CYCLIC TEST soft key to activate (= LOW, open collector) all outputs successively for 1 second.
- ▶ To exit the cyclic test, press the CURRENT STATE soft key or the C hard key.

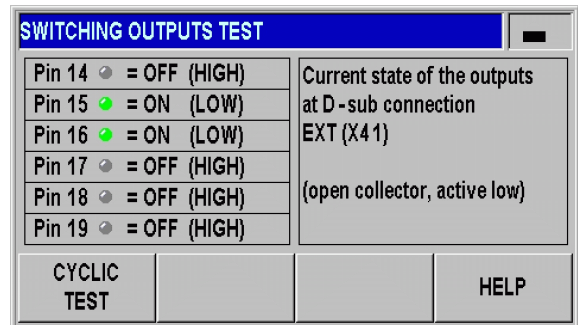

Fig. II.54 Switching outputs test



II – 3 Switching Inputs and Outputs

Switching inputs at D-sub connection X41



Danger to internal components!

- The power supply of external circuits must comply with **EN 50178 requirements for low voltage electrical separation.**
- Connect inductive loads only with a **quenching diode parallel to the inductance.**



Danger to internal components!

Use only shielded cables and **connect the shield to the connector housing.**

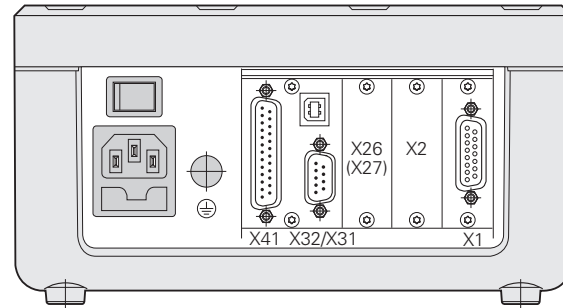

Fig. II.55 Connections

Pin	Function	See page
1, 10	0 V	
2	Reset to zero, clear error message	Page 31
3	Set axis / coupled axes to value for datum point	
4	Ignore reference mark signals (X1)	Page 95
5	Start series of measurements / f(X1,X2) display	Page 40
6	Externally select display value for series of measurements / X1 display	
7	Display minimum value of series of measurements / X2 display	
8	Display maximum value of series of measurements / X1+X2 display	
9	Display difference MAX-MIN of series of measurements / X1-X2 display	
22	Pulse: Transmit measured value	Page 95 and Page 44
23	Contact: Transmit measured value	
24	Ignore reference mark signals (X2, optional)	Page 95
25	Enable or disable REF mode (current REF status is changed)	Page 22
12, 13	Do not assign	
11, 20, 21	Vacant	





Special case:

If you want to display the current measured value **ACTL** of a measurement series, the following applies for inputs **7**, **8** and **9**: Either none or more than one of these inputs must be active.

Input signals

Signal	Value
Internal pull-up resistor	1kΩ active Low
Activation	Trigger by making contact against 0 V or by low-level signal over TTL logic device (see "Measured value output after a trigger signal" on page 114)
Delay time for preset/reset	$t_V \leq 2$ ms
Minimum pulse duration for all signals (except for pin 22 and 23: see Page 114)	$t_{min} \geq 30$ ms

Signal level of inputs

Status	Level
High	+ 3.9 V ≤ U ≤ + 15 V
Low	- 0.5 V ≤ U ≤ + 0.9 V; I ≤ 6 mA

Ignoring the reference mark signals

If the input at **pin 4** is active, the ND will ignore the reference mark signals of axis **X1**. If the input at **pin 24** is active, the ND will ignore the reference mark signals of axis **X2** (optional). A typical application of this function is for measuring lengths with a rotary encoder and leadscrew; in this case, a cam switch releases the reference mark signal at a preset position.

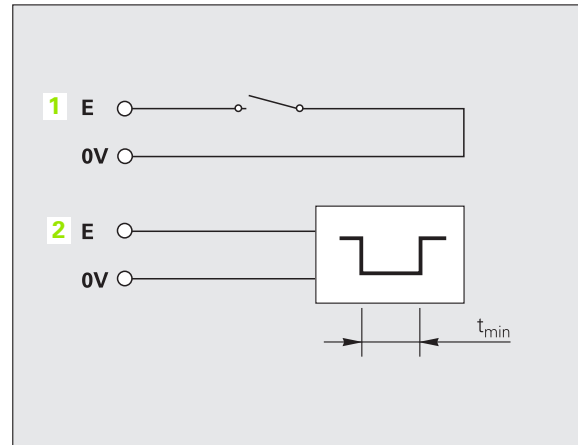

Fig. II.56 Switching inputs for measured value output at X41; 1: Contact, 2: Pulse



Switching outputs at D-sub connection X41



Danger to internal components!

- The power supply of external circuits must comply with **EN 50178 requirements for low voltage electrical separation**.
- Connect inductive loads only with a **quenching diode parallel to the inductance**.



Danger to internal components!

Use only shielded cables and **connect the shield to the connector housing**.

Pin	Function
14	Display value is zero
15	Measured value is greater than or equal to trigger limit A1
16	Measured value is greater than or equal to trigger limit A2
17	Measured value is less than the lower sorting limit
18	Measured value is greater than the upper sorting limit
19	Error (see "Error messages" on page 60)

Output signals

Signal	Value
Open-collector outputs	Active Low
Delay until signal output	$t_V \leq 20 \text{ ms}$
Signal duration of zero crossover, trigger limit A1, A2	$t_0 \geq 180 \text{ ms}$

Signal level of outputs

Status	Level
High	$U \leq + 32 \text{ V}; I \leq 10 \text{ }\mu\text{A}$
Low	$U \leq + 0.4 \text{ V}; I \leq 100 \text{ mA}$

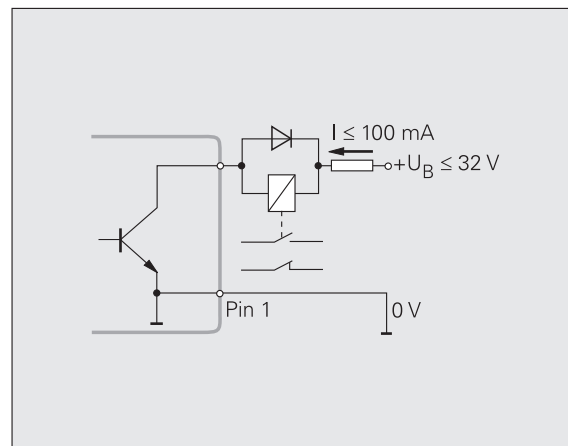

Fig. II.57 Open-collector outputs



Trigger limits

As soon as the trigger limit **1** defined by parameter is reached (see figure at right), the corresponding output **2** is activated (3: path). You can set up to two trigger limits: A1 and A2 (see "Switching signals" on page 38). A separate output is available for the zero crossover (see "Zero crossover" on page 98).

In the **Distance-To-Go** operating mode, switching outputs **A1** (pin 15) and **A2** (pin 16) have a different function: They are symmetrical about zero. For example, if a trigger point of 10 mm is entered for A1, then output A1 switches at both +10 mm and -10 mm. Fig. II.59 shows output signal A1 when traversing to display value zero from the negative direction: $A1 = 10$ mm, $t_{v1} \leq 30$ ms, $t_{v2} \leq 180$ ms.

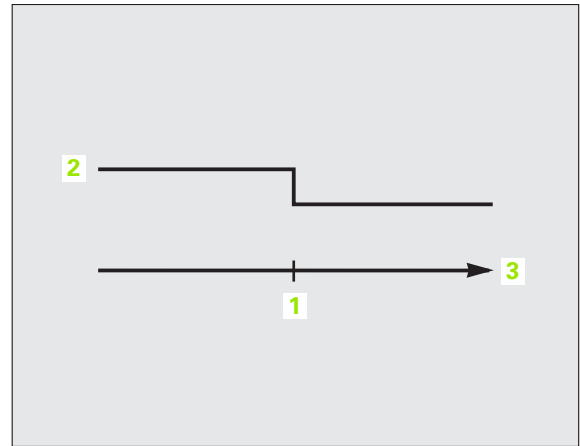

Fig. II.58 Trigger limit A1

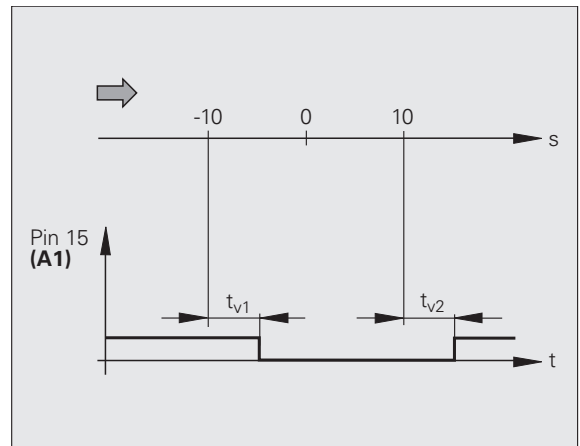

Fig. II.59 Time curve of signal at pin 15 for trigger limit A1 = 10 mm



Sorting limits

If the measured value exceeds the sorting limits, the ND activates the outputs at **pin 17** or **pin 18** (see "Sorting and Tolerance Checking" on page 58).

Example: See figure at upper right.

- **1**: Lower limit
- **2**: Upper limit
- **3**: Measured value < Lower sorting limit
- **4**: Measured value > Upper sorting limit

Trigger signal for error

The ND constantly monitors the measuring signal, the input frequency, the data output, etc., and displays an error message if it detects an error. If errors occur that seriously influence measurement or data output, the ND activates the output at **pin 19**. This feature allows monitoring of automated processes.

Zero crossover

If the display value is zero, the ND activates the output at **pin 14**. The minimum signal duration is 180 ms.

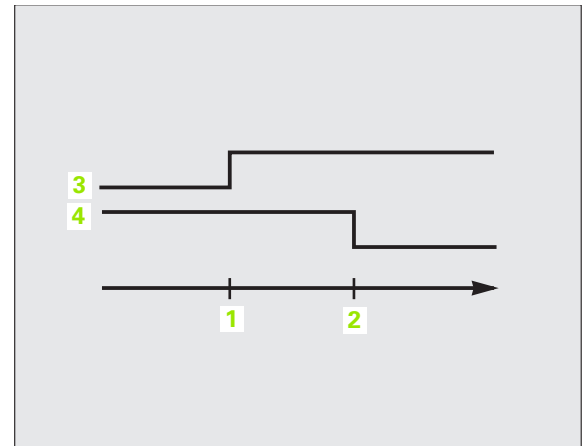

Fig. II.60 Sorting limits

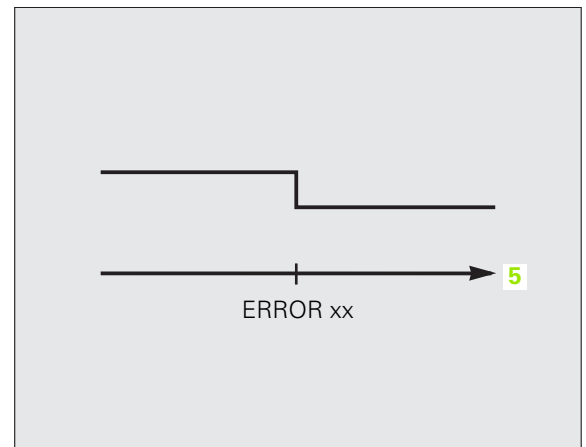

Fig. II.61 Trigger signal for error **5**: Time

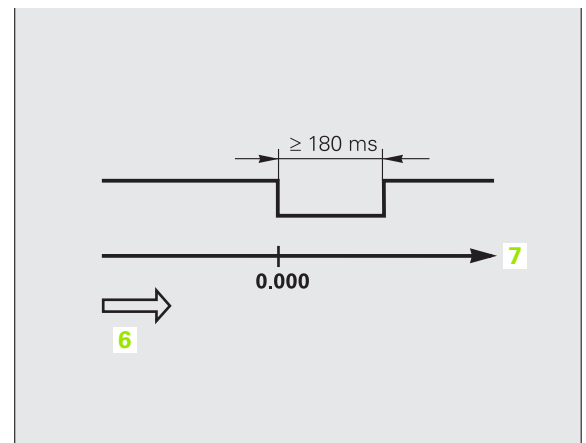

Fig. II.62 Zero crossover; **6**: Direction of traverse; **7**: Path

II – 4 Encoder Parameters

Table values

The following tables represent a partial list of HEIDENHAIN encoders. These tables describe the operating parameters which you must set for the encoders. Most entries can be found in the operating instructions for your encoder.

HEIDENHAIN linear encoders

Encoder	Signal period	Reference marks
SPECTO ST 12/30	20 µm	Single
METRO MT 60/101	10 µm	Single
METRO MT 12xx/25xx	2 µm	Single
CERTO CT 25xx/60xx	2 µm	Single
LS 388C	20 µm	Coded/1000
LS 487 LS 487C	20 µm	Single Coded/1000
LS 186 LS 186C	20 µm	Single Coded/1000
LF 183 LF 183C	4 µm	Single Coded/5000
LB 382 LB 382C	40 µm	Single Coded/2000
LC 183 LC 483	Self-configuring	None Absolute
LIDA 18x LIDA 48x	40 µm	Single
LIDA 28x	200 µm	Single
LIDA 583	20 µm	Single
LIF 181R LIF 181C	8 µm	Single Coded/5000
LIF 581R LIF 581C	8 µm	Single Coded/5000



HEIDENHAIN angle encoders

Encoder	Signal period	Reference marks
ROD 48x ERN x80	1000 ... 5000	Single
ROC 425 ECN x25	Self-configuring	None Absolute
ROQ 437 EQN 437	Self-configuring	None Absolute
ROD 280 ROD 280C	18000	Single Coded/36
RON 28x RON 28xC	18000	Single Coded/36
RON 785 RON 785C	18000	Single Coded/36
RON 886 RON 886C	36000	Single Coded/72
RCN 22x	Self-configuring	None Absolute
RCN 729 RCN 829	Self-configuring	None Absolute



II – 5 Data Interface

Data communication

The ND 287 features two serial interfaces: **RS-232/V.24 (X31)** and **USB (UART, X32)**.



Danger to internal components!

The interfaces X31 and X32 comply with the requirements of EN 50 178 for **low voltage electrical separation**.

Do not engage or disengage any connections while the unit is under power.

The serial ports support both bi-directional data communication, which allows data to be exported to or imported from an external device, and external operation of the ND 287 via the data interface.



As an option, an Ethernet module (100baseT) can be connected to X26/X27 so that an Ethernet interface is available to connect the ND to a network via the TCP/IP protocol.

Data which can be exported from the ND 287 to an external serial device includes:

- Job and installation configuration parameters
- Non-linear error compensation tables
- Measured value output

Data which can be imported into ND 287 from an external device includes:

- Key commands
- Job and installation configuration parameters
- Non-linear error compensation tables
- Software updates (firmware update)

This chapter covers what you need to know about **setting up** the data interface:

- Serial data transfer with the Import or Export function
- Software update (firmware update) installation
- Wiring of the connecting cable at the ND 287
- External operation

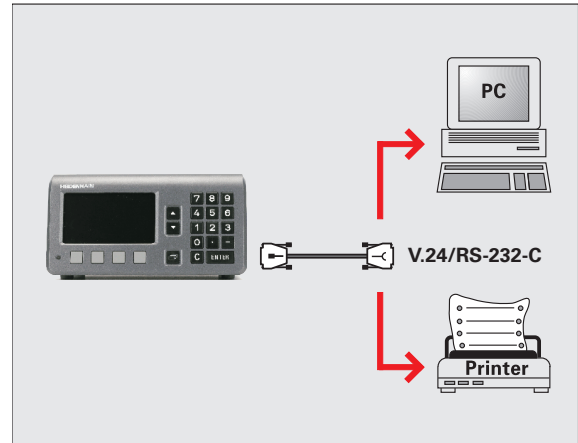

Fig. II.63 Data communication via RS-232-C/V.24



Serial data transfer with the Import or Export function

The serial ports **RS-232/V.24 (X31)** and **USB Type B (UART, X32)** are located on the rear panel. The following devices can be connected to these ports (see "Wiring the connecting cable" on page 105):

- Printer with serial data interface
- Personal computer (PC) with serial data interface



Danger to internal components!

The interfaces X31 and X32 comply with the requirements of EN 50 178 for **low voltage electrical separation**.

Do not engage or disengage any connections while the unit is under power.

Define the system parameters for data transfer (see "Setting up the serial port" on page 86).

For operations that support data transfer, the ND 287 displays the IMPORT/EXPORT soft key. Press this soft key to call the two following soft keys:

- Press IMPORT to receive data from a computer.
- Press EXPORT to send data to a computer or printer.

Data transfer from the ND 287 to a printer

To export data to a serial port **printer**, press the EXPORT soft key. The ND 287 exports the data in an ASCII text format which can be printed directly.

Data transfer from the ND 287 to a PC

To export or import data between the ND 287 and a PC, the PC must use terminal communications software, such as HyperTerminal, which is included with Windows®, or **TNCremoNT**. TNCremoNT is available from HEIDENHAIN free of charge. You will find the software on the HEIDENHAIN web site at www.heidenhain.de on the downloads page under **Services and Documentation**.

Contact your HEIDENHAIN distributor for further details. This software processes the data being sent or received over the serial cable link. All data transferred between the ND 287 and the PC is in ASCII text format.

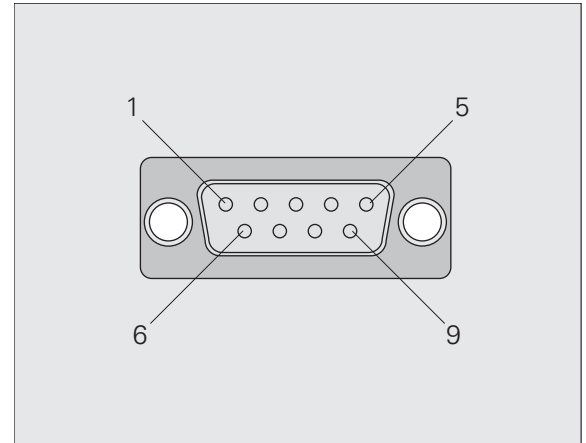

Fig. II.64 Connector for RS-232-C/V.24

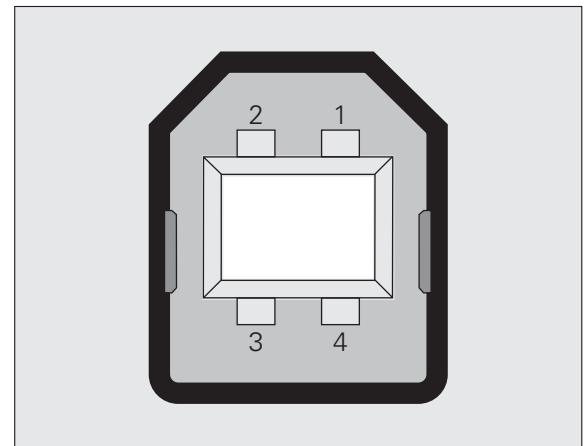

Fig. II.65 USB Type B socket (UART)



To export data from the ND 287 to a PC, the PC must first be made ready to receive the data to save it to a file. Set up the terminal communication program to capture ASCII text data from the COM port to a file on the PC. After the PC is ready to receive, start the data transfer by pressing the ND 287's EXPORT soft key.

Importing data into the ND 287 from a PC

To import data into the ND 287 from a PC, the ND 287 must first be made ready to receive the data:

- ▶ Press the IMPORT soft key. After the ND 287 is ready, set up the terminal communications program on the PC to send the desired file in ASCII text format.

Data format

The data format can be defined in the INSTALLATION SETUP menu under INTERFACE SETTINGS (see "Setting up the serial port" on page 86).



The ND 287 does not support communication protocols such as Kermit or Xmodem.

Control characters

Measured value retrieval:	STX (CTRL B)
Interruption:	DC3 (CTRL S)
Continuation:	DC1 (CTRL Q)
Error message enquiry:	ENQ (CTRL E)

For examples of measured value output, refer to "Measured Value Output" on page 114.



Software update (firmware update) installation

If required, you can download a software update (firmware update) for your ND from the HEIDENHAIN web site. You will find the update at www.heidenhain.de on the downloads page under **Services and Documentation**.

To install the software update (firmware update):

- ▶ Connect your PC to the serial port **USB Type B (UART, X32)**, see "Wiring the connecting cable" on page 105.



Danger to internal components!

The interfaces X31 and X32 comply with the requirements of EN 50 178 for **low voltage electrical separation**.

Do not engage or disengage any connections while the unit is under power.



A software update can be installed only over the USB interface, and **not** over the **RS-232/V.24 (X31)** interface.

- ▶ The device driver must be installed on your PC in order to transmit data over the USB port, see "Wiring the connecting cable" on page 105.
- ▶ Double-click the file to start the software update (firmware update) on the PC.
- ▶ **Simultaneously** press and hold the C key and the ENTER key on the ND **while switching the ND on**. The ND displays the currently installed hardware and firmware versions and is now ready for a software download (firmware download), see Fig. II.66.
- ▶ Start the update by pressing the **Start** button on the PC.
- ▶ Wait until the software installation (firmware) has been completed. The ND will automatically restart and will then display the **initial screen**.
- ▶ Press the LANGUAGE soft key if you want to change the conversational language and press ENTER.
- ▶ Press any key to call the standard screen. The ND is now ready for operation (see "Switching on the ND 287" on page 21).
- ▶ Close the installation window on the PC.



Fig. II.66 Software update (firmware update)



Wiring the connecting cable

The wiring of the connecting cable depends on the device being connected (see technical documentation for external device).

Complete wiring of RS-232-C/V.24 (X31)

Before the ND 287 and your PC can communicate, they need to be connected to each other with a serial cable.

RS-232-C / V.24 data transfer cable D-sub (female) 9-pin/D-sub (female) 9-pin

ID 366964-xx

Pin	Assignment	Function
1	Do not assign	
3	TXD	Transmitted data
2	RXD	Received data
7	RTS	Request to send
8	CTS	Clear to Send
6	DSR	Data set ready
5	SIGNAL GND	Signal ground
4	DTR	Data terminal ready
9	Do not assign	

Signal level

Signal	Signal level "1"= "active"	Signal level "0"= "inactive"
TXD, RXD	-3 V to -15 V	+ 3 V to + 15 V
RTS, CTS DSR, DTR	+ 3 V to + 15 V	-3 V to -15 V

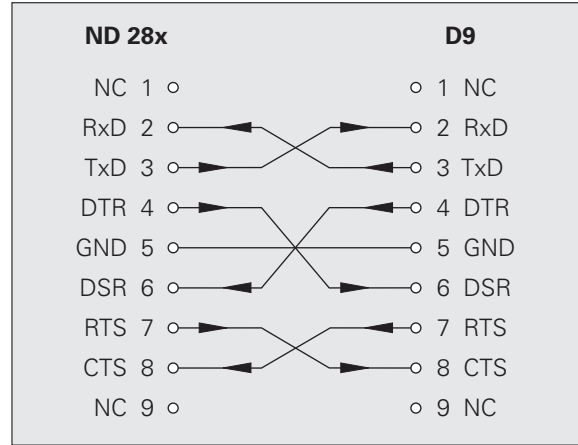

Fig. II.67 Pin assignment for serial port with handshaking

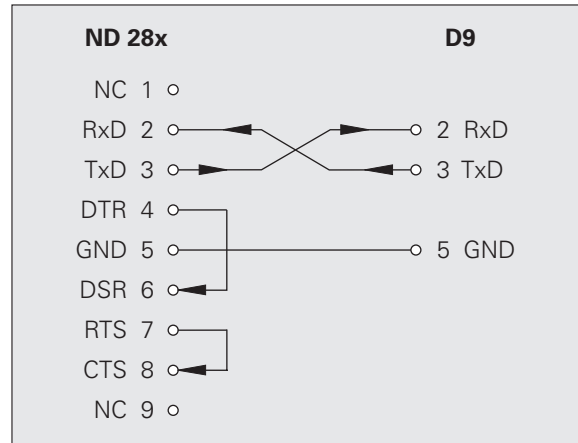

Fig. II.68 Pin assignment for serial port without handshaking



USB Type B (UART), socket as per IEC 61076-3-108

Pin	Assignment	Function
1	VCC	+5 V
2	D-	Data (inverse)
3	D+	Data
4	GND	Signal ground

If you want to connect your position display unit to a PC via the USB interface, you need a special USB driver. You will find the driver file for Windows 2000, XP and Vista in the installation directory of the TNCremo software or on the HEIDENHAIN web site at www.heidenhain.de on the downloads page under **Services and Documentation**.

After downloading the software, run the respective file. Then connect your position display unit to the PC, and switch the position display unit on. Then you can install the USB driver with the Windows hardware wizard, which will start automatically.

Cable length: Max. 5 m

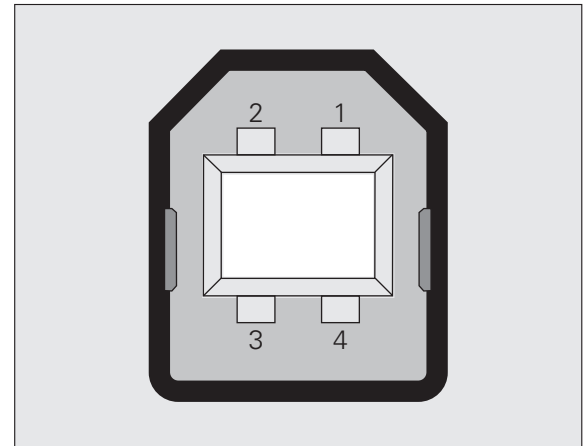

Fig. II.69 Pin assignment USB Type B socket

External operation via RS-232-C/V. 24 or USB interface

Key commands

You can operate the ND 287 remotely over the RS-232-C/V.24 (X31) or USB (UART, X32) data interface using an external device. The following key commands are available:

Format	
<ESC>TXXXX<CR>	Key is pressed
<ESC>AXXX<CR>	Output of screen contents
<ESC>FXXXX<CR>	Execute function
<ESC>SXXXX<CR>	Execute special function

Sequence of commands	Function
<ESC>T0000<CR>	Key '0'
<ESC>T0001<CR>	Key '1'
<ESC>T0002<CR>	Key '2'
<ESC>T0003<CR>	Key '3'
<ESC>T0004<CR>	Key '4'
<ESC>T0005<CR>	Key '5'
<ESC>T0006<CR>	Key '6'
<ESC>T0007<CR>	Key '7'
<ESC>T0008<CR>	Key '8'
<ESC>T0009<CR>	Key '9'
<ESC>T0100<CR>	CLEAR key
<ESC>T0101<CR>	Key '-'
<ESC>T0102<CR>	Key '.'
<ESC>T0103<CR>	Navigation key
<ESC>T0104<CR>	Key 'ENTER'
<ESC>T0105<CR>	Key 'Cursor Up'
<ESC>T0106<CR>	Key 'Cursor Down'
<ESC>T0107<CR>	Key 'Soft key 1' (left)
<ESC>T0108<CR>	Key 'Soft key 2'
<ESC>T0109<CR>	Key 'Soft key 3'



Sequence of commands	Function
<ESC>T0110<CR>	Key 'Soft key 4' (right)

Sequence of commands	Function
<ESC>A0000<CR>	Output of device identification
<ESC>A0100<CR>	Output of position display value
<ESC>A0200<CR>	Output of actual position
<ESC>A0301<CR>	Output of error message
<ESC>A0400<CR>	Output of software ID number
<ESC>A0800<CR>	Output of status bar
<ESC>A0900<CR>	Output of status indicators

Sequence of commands	Function
<ESC>F0000<CR>	Toggle REF function
<ESC>F0001<CR>	Start measurement series / SPC
<ESC>F0002<CR>	Print

Sequence of commands	Function
<ESC>S0000<CR>	Reset position display
<ESC>S0001<CR>	Lock keypad
<ESC>S0002<CR>	Release keypad

Description of key commands

The ND supports the XON-XOFF protocol when executing commands:

- As soon as the internal character buffer is full (100 characters), the ND sends the control character **XOFF** to the transmitter.
- After the buffer has been executed, the ND sends the control character **XON** to the transmitter and is then ready to receive data again.



Key is pressed (TXXXX commands)

- The ND acknowledges every correctly received key command by transmitting the control character **ACK** (Acknowledge, CTRL F). Then the ND executes the key command.
- The ND responds to commands that cannot be identified or to invalid commands by sending the control character **NAK** (No acknowledge, CTRL U).

Output of screen contents (AXXXX commands)

- The ND responds to valid commands by sending the control character **STX** (Start of text, CTRL B) before outputting the text.
- The ND responds to commands that cannot be identified or to invalid commands by sending the control character **NAK** (No acknowledge, CTRL U).

Output of device identification:

- Device name
- ID number of the currently installed software
- Version number of the currently installed software

<STX>					N	D	-	2	8	7	<CR>	<LF>
		6	4	6	1	1	8	-	0	1	<CR>	<LF>
						V	1	-	0	1	<CR>	<LF>
1	2									3		

- 1** STX control character: 1 character
- 2** Device identification: 10 characters
- 3** End of line: 2 characters

Output of position display value:

<STX>	-	1	2	3	4	5	.	6	7	8	9	<CR>	<LF>
4	5										6		

- 4** STX control character: 1 character
- 5** Displayed position value: 10 - 13 characters, depending on the number of decimal points and decimal places
- 6** End of line: 2 characters



Output of current position:

<STX>	+	1	2	3	4	5	6	7	8	9	<CR>	<LF>
7	8										9	

7 STX control character: 1 character

8 Current position: 10 characters, without decimal point, with leading zeros

9 End of line: 2 characters

Output of error message



- The error text displayed in the message line is transmitted.
- This functions only if an error message is displayed.

<STX>	E	R	R	O	R		X	1	:	I	N	P	U	T		F	R
	E	Q	U	E	N	C	Y		T	O	O		H	I	G	H	!
	<CR>																<LF>
10	11																12

10 STX control character: 1 character

11 Error message: 35 characters

12 End of line: 2 characters

Output of software ID number:

<STX>		6	3	7	4	5	6	-	0	1	<CR>	<LF>
13	14										15	

13 STX control character: 1 character

14 ID number of the currently installed software: 10 characters

15 End of line: 2 characters



Output of status bar:

<STX>	0	3	0	1	0	0	1	2	<CR>	<LF>
16	a	b	c	d	e	f	g	h	17	

16 STX control character: 1 character

a-h Parameter values of the status bar: 8 characters

17 End of line: 2 characters

Column	Parameter					
a	Operating mode	0 = Actual Value	1 = Distance-To-Go			
b	Display mode for axis and coupled axes	0 = X1	1 = X2	2 = X1 + X2	3 = X1 - X2	4 = f(X1, X2)
c	Scaling factor	0 = Not active	1 = Active			
d	Compensation	0 = No compensation		1 = Error compensation or axis-error compensation is active		
e	Stopwatch	0 = Stopped	1 = Stopwatch is running			
f	Unit of measure	0 = mm	1 = inches	2 = DEG	3 = DMS	4 = rad
g	Datum	1 = Datum 1	2 = Datum 2			
h	Soft-key page	1 = Page 1	2 = Page 2	3 = Page 3	4 = Keyboard is locked	



Output of status indicators

<STX>	0	1	0	0	1	0	0	0	0	1	<CR>	<LF>
18	a	b	c	d	e	f	g	h	i	j	19	

18 STX control character: 1 character

a-j Parameter values of the status display: 10 characters

19 End of line: 2 characters

The ND sends the status of the symbols in the status display:

0 = Symbol not active (gray)

1 = Symbol active (red)

2 = Symbol flashing

Column	Parameter	Meaning
a	<	Displayed tolerance checking and sorting mode
b	=	
c	>	
d	MIN	Currently active display mode of series of measurements
e	ACTL	
f	MAX	
g	DIFF	
h	SET	Datum setting
i	REF	Reference mark evaluation
j	Meas. series / SPC	0 = No measurement 1 = Measurement series / SPC has been started



Execute function (FXXXX commands)

- The ND acknowledges every correctly received key command by transmitting the control character **ACK** (Acknowledge, CTRL F). Then the ND executes the key command.
- The ND responds to commands that cannot be identified or to invalid commands by sending the control character **NAK** (No acknowledge, CTRL U).

Functions:

- **Toggle REF function:** Deactivate or activate REF mode (currently active REF status is changed).
- **Start meas. series / SPC:** Start a new series of measurements / SPC.
- **Print:** Transmit the current measured value; same function as **Output Measured Values** with STX (CTRL B, see "Measured Value Output" on page 114).

Execute special function (SXXXX commands)

Functions:

- **Reset the position display:** Function same as switching the position display unit off/on.
- **Lock keyboard:** The ND acknowledges the special function by transmitting the control character **ACK** (Acknowledge). All keys of the ND are locked. The ND can be operated only by external key commands. The keypad can be released either by transmitting the special function **Release keypad** or by switching the position display unit off and then back on.
- **Release keypad:** The ND acknowledges the special function by transmitting the control character **ACK** (acknowledgment). Then it releases the keypad that has been locked with **Lock keypad**.



II – 6 Measured Value Output

Alternatives for starting measured value output

With a PC, there are three different ways to start measured value output from the ND 287:

- After a **trigger signal at input X41** (see "Switching inputs at D-sub connection X41" on page 94)
- With **CTRL B** or the PRINT soft key over the serial port X31 or X32

Measured value output after a trigger signal

There are two ways to start measured value output over the interface (X41) (see Fig. II.70):

- ▶ Connect the **Contact** input (**pin 23** at X41) to **pin 1** or **pin 10** (0 V) via a standard switch.
- ▶ Or: Connect the **Pulse** input (**pin 22** at X41) to **pin 1** or **pin 10** (0 V) via a TTL logic device (such as SN74LSXX). Measured-value output is triggered by a pulse.

The ND 287 transmits the measured values according to the parameters defined in the JOB SETUP menu (see "Measured value output" on page 39) via the TXD line of the RS-232-C/V.24 interface or the USB interface.

Propagation times

Process	Time
Minimum duration t_e of Contact signal	$t_e \geq 7 \text{ ms}$
Minimum duration t_e of Pulse signal	$t_e \geq 1.5 \mu\text{s}$
Latching delay t_1 after Contact	$t_1 \leq 5 \text{ ms}$
Latching delay t_1 after Pulse	$t_1 \leq 1 \mu\text{s}$
Measured-value output after t_2	$t_2 \leq 50 \text{ ms}$
Regeneration time t_3	$t_3 \geq 0 \text{ ms}$

Duration of measured value transfer

$$t_D = \frac{187 + (11 \cdot L)}{B}$$

t_D : Duration of measured value transfer in [s]

L: Number of blank lines

B: Baud rate

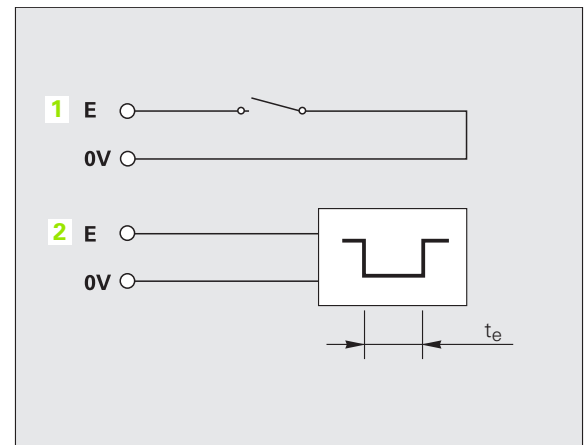

Fig. II.70 Switching inputs for measured value output at X41; 1: Contact, 2: Pulse

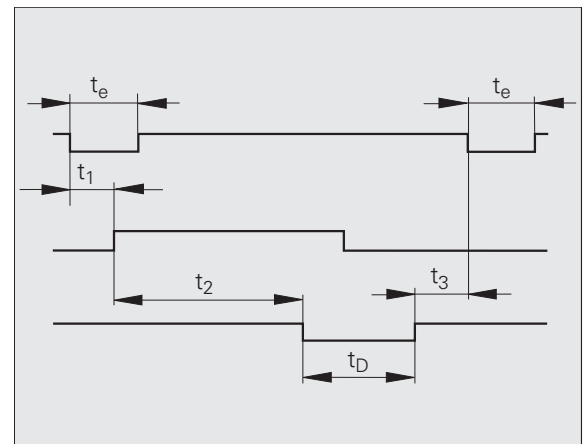

Fig. II.71 Propagation times for measured value output after contact or pulse

Measured-value output via the serial data interface X31 or X32



Danger to internal components!

The interfaces X31 and X32 comply with the requirements of EN 50 178 for **low voltage electrical separation**.

Do not engage or disengage any connections while the unit is under power.

Use the PRINT soft key or the **CTRL B** command to transmit the currently displayed values in either Actual Value or Distance-To-Go mode, whichever is currently active (see "Operating modes" on page 30), via either the RS-232-C/V.24 or the USB interface to a PC.

CTRL B command:

- RS-232-C/V.24 interface:
If the ND receives the **CTRL B** command over the RXD line of the interface, it transmits the measured values back over the TXD line (see "Data Interface" on page 101).
- USB Type B:
This interface supports bidirectional data communication. Data transfer is started with the **CTRL B** command.

Data transfer:

- The measured values can be received and saved using a terminal program (e. g. HyperTerminal, which is included with Windows®). You can also use the **TNCremoNT** software. TNCremoNT is available from HEIDENHAIN free of charge. You will find the software at www.heidenhain.de on the downloads page under **Services and Documentation**.
- The basic program (see Fig. II.72) shows the fundamental structure of a program for measured value output.

Propagation times

Event	Time
Latching delay t_1	$t_1 \leq 1$ ms
Measured-value output after t_2	$t_2 \leq 50$ ms
Regeneration time t_3	$t_3 \geq 0$ ms

```

10  L%=18
20  CLS
30  PRINT "V.24/RS-232-C"
40  OPEN "COM1:9600,E,7" AS#1
50  PRINT #1, CHR$(2);
60  IF INKEY$<>" " THEN 130
70  C%=LOC(1)
80  IF C%<L% THEN 60
90  X$=INPUT$(L%,#1)
100 LOCATE 9,1
110 PRINT X$;
120 GOTO 50
130 END
    
```

Fig. II.72 Basic program for measured value output with CTRL B

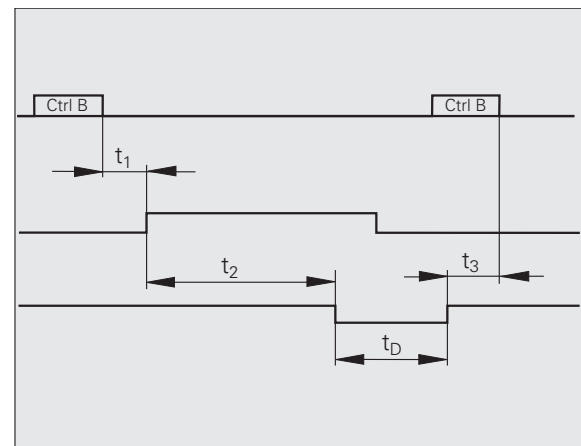

Fig. II.73 Propagation times for measured value output after CTRL B



Duration of measured value transfer

$$t_D = \frac{187 + (11 \cdot L)}{B}$$

t_D : Duration of measured value transfer in [s]

L: Number of blank lines

B: Baud rate

Example: Data sequence during measured-value output

Measured value: $X = -5.23$ mm

The measured value is within the sorting limits (=) and is the current value (A) of a series of measurements.

Measured-value output:

-	5.23			=	A	<CR>	<LF>
1	2	3	4	5	6	7	8

- 1 +/- sign
- 2 Numerical value with decimal point: 10 characters on the whole, leading zeros are output as blank spaces.
- 3 Blank space
- 4 Unit of measure: **Blank space** = mm, " = inches, ? = fault
- 5 Sorting status (< / = / >)
? = lower sorting limit > upper sorting limit
- 6
 - When series of measurements has been started:
S = MIN, **A** = ACTL, **G** = MAX, **D** = DIFF
 - If two axes are coupled (optional) and no series of measurements has been started:
1 = X1, **2** = X2, **A** = X1 + X2, **S** = X1 - X2, **F** = f(X1,X2)
- 7 Carriage return
- 8 Blank line (Line Feed)



II – 7 Input and Output of Parameter List and Error Compensation Table

Text file

You can receive the lists output by the ND via the serial data interface as **text files in ASCII format** and save them on your PC.

To export or import data between the ND 287 and a PC, the PC must use terminal communications software, such as HyperTerminal, which is included with Windows ®, or **TNCremoNT**. TNCremoNT is available from HEIDENHAIN free of charge. You will find the software at www.heidenhain.de on the downloads page under **Services and Documentation**.



- Each list must be saved as a **separate text file**.
- You can then use the terminal program to transmit the text files back to the ND.
- If you want, you can edit the text files with a **text editor** and change the parameter values, for example. However, this requires **knowledge of the different output formats of the lists** (see following pages). When receiving lists, the ND expects the same list structure as used for the output.
- When receiving lists, the ND firsts waits for the **starting character** < # >.
- The receiving mode ends as soon as the ND has received the **final character** < # >.

The lists received are first checked for the **type** of position display unit (line 2 of output list). The receiving ND accepts only lists prepared by the same type of position display unit. For example, if the ND 287 receives a parameter list from the ND 280, it generates the message **"ERROR DURING RECEPTION Incorrect data file."** in the window to the right. Acknowledge the message with the C key.

Furthermore, the ND checks the list for **completeness**. Lists that contain, for example, too many or too few parameters are ignored. If an error occurs, the ND also displays an error message: **ERROR DURING RECEPTION Incorrect data file**. Acknowledge the error message with the C key.



If the ND receives **invalid parameter values**, it sets the respective operating parameters to the **default settings**.

Example: P01 LINEAR = 3

The value **3** is not allowed. The parameter P01 is set to the default setting: P01 LINEAR = 0



Examples for parameter lists



The parameter text is always sent in English.

The parameter value, not the text, is definitive when the parameters are transferred to the ND. The values in **boldface type** are the default settings.

ND 287 with rotary encoder connected to input X1

Parameter	Meaning
#	Start character (#)
ND-287 1 DEG	Model: ND-287, Unit of measure: DEG, DMS or rad
P01 LINEAR =	0 Unit of measure for linear dimensions: mm = 0 , inches = 1
P02 ANGULAR =	0 Unit of measure for angular dimensions: DEG = 0 , DMS = 1, rad = 2
P03 ENC. TYPE =	1 Encoder type: Linear = 0 , Rotary = 1
P04 ENC. SIGNAL =	1 Encoder signal: 0 = 11 μ A, 1 = 1 Vpp , 2 = Endat, 3 = ANALOG
P05 AXES DISPL. =	0 Display: 0 = X1 , 1 = X2, 2 = X1 + X2, 3 = X1 - X2, 4 = f(X1,X2)
P06 ANGLE =	0 Angle format: 0 = +/- 180° , 1 = 360°, 2 = +/- infinity
P10 SCALING =	0 Scaling: 0 = off , 1 = on
P11 SCL. FACTOR = + 1.000000	Scale factor = 1.000000 (default setting)
P20 BRIGHTNESS =	94 Brightness of LCD screen: 0 - 100% (80% is the default setting)
P21 DISP. SAVER =	1 Screen saver: 0 = off, 1 = on
P22 SAVERTIME =	120 Idle time before screen saver is activated: 120 min (default setting)
P23 START.DISPL. =	1 Power-up screen: 0 = off, 1 = on
P30 DIRECTION =	0 Count direction: 0 = positive , 1 = negative
P31 SIGN.PERIOD =	20 Signal period: 20 μ m (10 μm is the default setting)
P32 SP/R =	36000 Signal period per revolution: 36000 is the default setting
P33 COUNT MODE =	5 Counting mode: 0 - 5 = 5 , 0 - 2 = 2, 0 - 1 = 1
P34 DP PLACES =	4 Decimal places: 4 (default setting)
P35 REF ON/OFF =	1 Reference mark: 0 = off, 1 = on
P36 REF MARK =	5 0 = single reference mark , 1..6: coded reference marks
P37 ALARM =	3 0 = off, 1 = frequency, 2 = contamination, 3 = frequency and contamination
P38 EXT. REF =	1 External REF input: 0 = inactive , 1 = active
P40 ENC. COMP. =	2 Axis error compensation: 0 = off , 1 = linear, 2 = non-linear



II – 7 Input and Output of Parameter List and Error Compensation Table

Parameter		Meaning	
P41	LIN. COMP. = + 0.0	Linear compensation: 0.0 µm/m (default setting)	
P43	ANALOG U1 = + 10.000	Analog module: Voltage 1 = 10.000 V (default setting)	
P44	ANALOG U2 = - 10.000	Analog module: Voltage 2 = -10.000 V (default setting)	
P45	ANALOG.POS1 = + 10.0000	Analog module: Position 1 (10.000 is the default setting)	
P46	ANALOG.POS2 = - 10.0000	Analog module: Position 2 (-10.000 is the default setting)	
P47	ANALOG FCT = + 9.4	Temperature compensation: Coefficient +9.4 µm/m·K (default setting)	
P48	REF. TEMP. = + 20.00	Temperature compensation: Reference temperature +20 °C (default setting)	
P49	ANALOG.COMP. = 1	Temperature compensation: 0 = off, 1 = on	
P50	RS232/USB = 1	Interface: 0 = RS232 , 1 = USB	
P51	BAUD RATE = 11	Baud rate = 115200 (0 - 11), 7 is the default setting	
P52	DATA BIT = 0	Data bits: 0 = 7 bits , 1 = 8 bits	
P53	STOP BIT = 0	Stop bit: 0 = 2 stop bits , 1 = 1 stop bit	
P54	PARITY BIT = 1	Parity bit: 0 = none, 1 = even , 2 = odd	
P55	BLANK LINE = 1	Blank lines: 1 (0 - 99)	
P56	DISP.FREEZE = 0	Display freeze: 0 = current , 1 = frozen, 2 = stopped	
P60	PRESET = + 0.0000	Value for preset via external signal: 0.0000	
P61	A1 ON/OFF = 1	Switching output A1: 0 = off, 1 = on	
P62	A2 ON/OFF = 1	Switching output A2: 0 = off, 1 = on	
P63	LIMIT A1 = + 0.0000	Value for switching output A1: 0.0000	
P64	LIMIT A2 = + 0.0000	Value for switching output A2: 0.0000	
P70	SORTING = 1	Sorting and tolerance checking: 0 = off , 1 = on	
P71	LOWER.LIMIT = - 25.4000	Value for lower sorting limit (SPC), 0.0000 is the default setting	
P72	UPPER.LIMIT = + 25.8000	Value for upper sorting limit (SPC), 0.0000 is the default setting	
P73	SORT.COLOR = 1	Display color during sorting: 0 = blue , 1 = red, green	
P74	EXT.INPUTS = 0	Function of external inputs: 0 = version 1 , 1 = version 2 (X1+X2...)	
P75	SERIES.MEAS. = 2	Measurement series display: 0 = off 1 = MIN, 2 = ACTL , 3 = MAX, 4 = DIFF	
P76	RECORD VAL. = 1	Measured value recording: 0 = off , 1 = on	
P77	LATCH = 2	Latching: 0 = interval , 2 = external signal, 3 = ENTER key	
P78	NUMBER VAL. = 10	Number of measured values: 10 (0 - 10000), 0 is the default setting	



Parameter		Meaning	
P79	TIMESEC =	5	Time slot for measurement series in seconds: 5 s, 0 s is the default setting
P80	TIME MIN =	0	Time slot for measurements series in minutes: 0 min is the default setting
P81	TIME H =	0	Time slot for measurement series in hours: 0 h is the default setting
P82	INTERVALL =	0	Sampling interval for measurement series: 20 ms - 10 sec, 0 ms is the default setting
P83	MEAS./SPC =	1	Measurement series / SPC: 1 = SPC active, 0 = measurement series active
P84	LATCHSPC =	0	Measured value latching (SPC): 0 = ENTER key, 1 = external signal
P85	MODELSPC =	0	SPC distribution model: 0 = symmetrical , 1 = left-hand limit, 2 = right-hand limit
P86	NR. SAMPLE =	25	Number of samples: 25 is the default setting
P87	VAL./SAMPLE =	3	Number of measured values per sample: 5 is the default setting
P88	NOM. VALUE = +	0.0000	Nominal value (mean tolerance value) for SPC: 0.0000 is the default setting
P89	UCL-X = +	0.0000	Value for upper control limit (SPC: X control chart): 0.0000 is the default setting
P90	LCL-X = +	0.0000	Value for lower control limit (SPC: X control chart): 0.0000 is the default setting
P91	UCL-S = +	0.0000	Value for upper control limit (SPC: S control chart): 0.0000 is the default setting
P92	UCL-R = +	0.0000	Value for upper control limit (SPC: R control chart): 0.0000 is the default setting
P96	LANGUAGE =	0	National language: 0 - 9, 0 = English
P97	FORM.LENGTH =	31	Length of the formula for function f(X1,X2): 14 is the default setting
P98	FORMULA = f(X1:X2)=X1+X2		Formula for function f(X1,X2) = X1 + X2
#			Final character (#)



II – 7 Input and Output of Parameter List and Error Compensation Table

ND 287 with two rotary encoders connected to inputs X1 and X2 (optional)

Parameter		Meaning	
#		Start character (#)	
ND-287 2	DEG	Model: ND-287, Unit of measure: DEG, DMS or rad	
P01	LINEAR =	0	Unit of measure for linear dimensions: mm = 0 , inches = 1
P02	ANGULAR =	0	Unit of measure for angular dimensions: DEG = 0 , DMS = 1, rad = 2
P03.1	ENC. TYPE =	1	X1: Encoder type: linear = 0 , rotary = 1
P03.2	ENC. TYPE =	1	X2: Encoder type: linear = 0 , rotary = 1
P04.1	ENC. SIGNAL =	1	X1: Encoder signal: 0 = 11 μ A, 1 = 1 Vpp , 2 = Endat, 3 = ANALOG
P04.2	ENC. SIGNAL =	1	X2: Encoder signal: 0 = 11 μ A, 1 = 1 Vpp , 2 = Endat, 3 = ANALOG
P05	AXES DISPL. =	0	Display: 0 = X1 , 1 = X2, 2 = X1 + X2, 3 = X1 - X2, 4 = f(X1,X2)
P06.1	ANGLE =	0	X1: Angle format: 0 = +/- 180° , 1 = 360°, 2 = +/- infinity
P06.2	ANGLE =	0	X2: Angle format: 0 = +/- 180° , 1 = 360°, 2 = +/- infinity
P10.1	SCALING =	0	X1: Scaling: 0 = off , 1 = on
P10.2	SCALING =	0	X2: Scaling: 0 = off , 1 = on
P11.1	SCL. FACTOR =	+ 1.000000	X1: Scale factor = 1.000000 (default setting)
P11.2	SCL. FACTOR =	+ 1.000000	X2: Scale factor = 1.000000 (default setting)
P20	BRIGHTNESS =	94	Brightness of LCD screen: 0 - 100% (80% is the default setting)
P21	DISP. SAVER =	1	Screen saver: 0 = off, 1 = on
P22	SAVERTIME =	120	Idle time before screen saver is activated: 120 min
P23	START.DISPL. =	1	Power-up screen: 0 = off, 1 = on
P30.1	DIRECTION =	0	X1: Count direction: 0 = positive , 1 = negative
P30.2	DIRECTION =	0	X2: Count direction: 0 = positive , 1 = negative
P31.1	SIGN.PERIOD =	20	X1: Signal period: 20 μ m (10 μm is the default setting)
P31.2	SIGN.PERIOD =	20	X2: Signal period: 20 μ m (10 μm is the default setting)
P32.1	SP/R =	36000	X1: Signal period per revolution: 36000 is the default setting
P32.2	SP/R =	36000	X2: Signal period per revolution: 36000 is the default setting
P33.1	COUNTMODE =	5	X1: Counting mode: 0 - 5 = 5 , 0 - 2 = 2, 0 - 1 = 1
P33.2	COUNTMODE =	5	X2: Counting mode: 0 - 5 = 5 , 0 - 2 = 2, 0 - 1 = 1
P34.1	DP PLACES =	4	X1: Decimal places: 4 (default setting)



Parameter		Meaning	
P34.2	DPPLACES =	4	X2: Decimal places: 4 (default setting)
P35.1	REF ON/OFF =	1	X1: Reference mark: 0 = off, 1 = on
P35.2	REF ON/OFF =	1	X2: Reference mark: 0 = off, 1 = on
P36.1	REF MARK =	5	X1: 0 = single reference mark , 1..6: coded reference marks
P36.2	REF MARK =	5	X2: 0 = single reference mark , 1..6: coded reference marks
P37.1	ALARM =	3	X1: 0 = off, 1 = frequency, 2 = contamination, 3 = frequency and contamination
P37.2	ALARM =	3	X2: 0 = off, 1 = frequency, 2 = contamination, 3 = frequency and contamination
P38	EXT. REF =	1	External REF input: 0 = inactive , 1 = active
P40.1	ENC. COMP. =	2	X1: Axis error compensation: 0 = off , 1 = linear, 2 = non-linear
P40.2	ENC. COMP. =	2	X2: Axis error compensation: 0 = off , 1 = linear, 2 = non-linear
P41.1	LIN. COMP. = +	0.0	X1: Linear compensation: 0.0 µm/m (default setting)
P41.2	LIN. COMP. = +	0.0	X2: Linear compensation: 0.0 µm/m (default setting)
P43.1	ANALOG U1 = +	10.000	X1: Analog module: Voltage 1 = 10.000 V (default setting)
P43.2	ANALOG U1 = +	10.000	X2: Analog module: Voltage 1 = 10.000 V (default setting)
P44.1	ANALOG U2 = -	10.000	X1: Analog module: Voltage 2 = -10.000 V (default setting)
P44.2	ANALOG U2 = -	10.000	X2: Analog module: Voltage 2 = -10.000 V (default setting)
P45.1	ANALOG.POS1= +	10.0000	X1: Analog module: Position 1 (10.000 is the default setting)
P45.2	ANALOG.POS1= +	10.0000	X2: Analog module: Position 1 (10.000 is the default setting)
P46.1	ANALOG.POS2= -	10.0000	X1: Analog module: Position 2 (-10.000 is the default setting)
P46.2	ANALOG.POS2= -	10.0000	X2: Analog module: Position 2 (-10.000 is the default setting)
P47	ANALOGFCT = +	9.4	Temperature compensation: Coefficient +9.4 µ/K (default setting)
P48	REF. TEMP. = +	20.00	Temperature compensation: Reference temperature +20.0 ° (default setting)
P49	ANALOG.COMP. =	1	Temperature compensation: 0 = off, 1 = on
P50	RS232/USB =	1	Interface: 0 = RS232 , 1= USB
P51	BAUDRATE =	11	Baud rate = 115200 (0 - 11), 7 is the default setting
P52	DATA BIT =	0	Data bits: 0 = 7 bits , 1 = 8 bits
P53	STOP BIT =	0	Stop bit: 0 = 2 stop bits , 1 = 1 stop bit
P54	PARITY BIT =	1	Parity bit: 0 = none, 1 = even , 2 = odd



II – 7 Input and Output of Parameter List and Error Compensation Table

Parameter		Meaning	
P55	BLANKLINE =	1	Blank lines: 1 (0 - 99)
P56	DISP.FREEZE =	0	Display freeze: 0 = current , 1 = frozen, 2 = stopped
P60	PRESET = +	0.0000	Value for preset via external signal: 0.0000
P61	A1 ON/OFF =	1	Switching output A1: 0 = off, 1 = on
P62	A2 ON/OFF =	1	Switching output A2: 0 = off, 1 = on
P63	LIMITA1 = +	0.0000	Value for switching output A1: 0.0000
P64	LIMITA2 = +	0.0000	Value for switching output A2: 0.0000
P70	SORTING =	1	Sorting and tolerance checking: 0 = off , 1 = on
P71	LOWER.LIMIT = -	25.4000	Value for lower sorting limit (SPC), 0.0000 is the default setting
P72	UPPER.LIMIT = +	25.8000	Value for upper sorting limit (SPC), 0.0000 is the default setting
P73	SORT.COLOR =	1	Display color during sorting: 0 = blue , 1 = red, green
P74	EXT.INPUTS =	0	Function of external inputs: 0 = version 1 , 1 = version 2 (X1+X2...)
P75	SERIES.MEAS. =	2	Measurement series display: 0 = off 1 = MIN, 2 = ACTL , 3 = MAX, 4 = DIFF
P76	RECORDVAL. =	1	Measured value recording: 0 = off , 1 = on
P77	LATCH =	2	Latching: 0 = interval , 2 = external signal, 3 = ENTER key
P78	NUMBERVAL. =	10	Number of measured values: 10 (0 - 10000), 0 is the default setting
P79	TIME SEC =	5	Time slot for measurement series in seconds: 5 s, 0 s is the default setting
P80	TIME MIN =	0	Time slot for measurements series in minutes: 0 min is the default setting
P81	TIME H =	0	Time slot for measurement series in hours: 0 h is the default setting
P82	INTERVALL =	0	Sampling interval for measurement series: 20 ms - 10 sec, 0 ms is the default setting
P83	MEAS./SPC =	1	Measurement series / SPC: 1 = SPC active, 0 = measurement series active
P84	LATCH SPC =	0	Measured value latching (SPC): 0 = ENTER key, 1 = external signal
P85	MODEL SPC =	0	SPC distribution model: 0 = symmetrical , 1 = left-hand limit, 2 = right-hand limit
P86	NR. SAMPLE =	25	Number of samples: 25 is the default setting
P87	VAL./SAMPLE =	3	Number of measured values per sample: 5 is the default setting
P88	NOM.VALUE = +	0.0000	Nominal value (mean tolerance value) for SPC: 0.0000 is the default setting
P89	UCL-X = +	0.0000	Value for upper control limit (SPC: X control chart): 0.0000 is the default setting



Parameter			Meaning
P90	LCL-X = +	0.0000	Value for lower control limit (SPC: X control chart): 0.0000 is the default setting
P91	UCL-S = +	0.0000	Value for upper control limit (SPC: S control chart): 0.0000 is the default setting
P92	UCL-R = +	0.0000	Value for upper control limit (SPC: R control chart): 0.0000 is the default setting
P96	LANGUAGE =	0	National language: 0 - 9, 0 = English
P97	FORM.LENGTH =	31	Length of the formula for function f(X1,X2): 14 is the default setting
P98	FORMULA = f(X1:X2)=X1+X2		Formula for function f(X1,X2) = X1 + X2
#			Final character (#)



Output format of the error compensation table



The ND outputs a separate error compensation table for each axis to be compensated.

First line

Each error compensation table output begins with the start character <#> (HEX: 0x23).

#	<CR>	<LF>
1		

1 Start character and end of line: 3 characters

Second line

Model of position display unit and unit of measure

N	D	-	2	8	7	2									M	M			<CR>	<LF>
2													3			4				

2 Model of display unit, left-aligned: 13 characters

3 Unit of measure: 6 characters

4 End of line: 2 characters

Third line

Output of axis to be compensated:

A	X	I	S		X	1									=					0	<CR>	<LF>
5													6			7			8			

5 Axis to be compensated, left-aligned: 13 characters

6 Separator block: 3 characters

7 Axis value, right-aligned: 6 characters

8 End of line: 2 characters



Examples of error compensation tables

ND 287 with linear encoder connected to input X1

Parameter		Meaning	
#			Start character (#)
ND-287 1	MM		Model: ND-287, unit of measure MM or IN (inches)
AXIS X1	=	0	Axis to be compensated
SPACING	= +	10.0000	Point spacing: 10 mm (value input)
DATUM	= +	0.0000	Datum: 0 mm (value input)
COMP.NO. 000	= +	0.0000 = + 0.0000	Compensation value 0 = 0.0000 mm (Compensation value 0 is always 0.0000 mm.)
COMP.NO. 001	= +	10.0000 = ...	Compensation value 1 = No value entered
COMP.NO. 002	= +	20.0000 = ...	Compensation values 2 - 199 = No values entered Axis will not be compensated.
COMP.NO. 003	= +	30.0000 = ...	
COMP.NO. 004	= +	40.0000 = ...	
COMP.NO. 005	= +	50.0000 = ...	
COMP.NO. 006	= +	60.0000 = ...	
COMP.NO. 007	= +	70.0000 = ...	
COMP.NO. 008	= +	80.0000 = ...	
COMP.NO. 009	= +	90.0000 = ...	
COMP.NO. 010	= +	100.0000 = ...	
COMP.NO. 011	= +	110.0000 = ...	
COMP.NO. 012	= +	120.0000 = ...	
COMP.NO. 013	= +	130.0000 = ...	
COMP.NO. 014	= +	140.0000 = ...	
COMP.NO. 015	= +	150.0000 = ...	
COMP.NO. 016	= +	160.0000 = ...	
COMP.NO. 017	= +	170.0000 = ...	
COMP.NO. 018	= +	180.0000 = ...	
...			
COMP.NO. 190	= +	1900.0000 = ...	



II – 7 Input and Output of Parameter List and Error Compensation Table

Parameter	Meaning
COMP.NO. 191 = + 1910.0000 =	...
COMP.NO. 192 = + 1920.0000 =	...
COMP.NO. 193 = + 1930.0000 =	...
COMP.NO. 194 = + 1940.0000 =	...
COMP.NO. 195 = + 1950.0000 =	...
COMP.NO. 196 = + 1960.0000 =	...
COMP.NO. 197 = + 1970.0000 =	...
COMP.NO. 198 = + 1980.0000 =	...
COMP.NO. 199 = + 1990.0000 =	...
#	Final character (#)



**ND 287 with two linear encoders connected to inputs X1 and X2
(optional)**

Parameter		Meaning	
#			Start character (#)
ND-287 2	MM		Model: ND-287, unit of measure MM or IN (inches)
AXIS X1	=	0	Axis to be compensated
X1 FCT X1	=	0	Error-causing axis
SPACING X1	= +	10.0000	Point spacing: 10 mm (value input)
DATUM X1	= +	0.0000	Datum: 0 mm (value input)
COMP.NO. 000	= +	0.0000 = + 0.0000	Compensation value 0 = 0.0000 mm (Compensation value 0 is always 0.0000 mm.)
COMP.NO. 001	= +	10.0000 =	...
COMP.NO. 002	= +	20.0000 =	...
COMP.NO. 003	= +	30.0000 =	...
COMP.NO. 004	= +	40.0000 =	...
COMP.NO. 005	= +	50.0000 =	...
COMP.NO. 006	= +	60.0000 =	...
COMP.NO. 007	= +	70.0000 =	...
COMP.NO. 008	= +	80.0000 =	...
COMP.NO. 009	= +	90.0000 =	...
COMP.NO. 010	= +	100.0000 =	...
COMP.NO. 011	= +	110.0000 =	...
COMP.NO. 012	= +	120.0000 =	...
COMP.NO. 013	= +	130.0000 =	...
COMP.NO. 014	= +	140.0000 =	...
COMP.NO. 015	= +	150.0000 =	...
COMP.NO. 016	= +	160.0000 =	...
COMP.NO. 017	= +	170.0000 =	...
COMP.NO. 018	= +	180.0000 =	...
...			
COMP.NO. 190	= +	1900.0000 =	...
COMP.NO. 191	= +	1910.0000 =	...

Compensation values 2 - 199 = No values entered
Axis will not be compensated.



II – 7 Input and Output of Parameter List and Error Compensation Table

Parameter	Meaning
COMP.NO. 192 = + 1920.0000 =	...
COMP.NO. 193 = + 1930.0000 =	...
COMP.NO. 194 = + 1940.0000 =	...
COMP.NO. 195 = + 1950.0000 =	...
COMP.NO. 196 = + 1960.0000 =	...
COMP.NO. 197 = + 1970.0000 =	...
COMP.NO. 198 = + 1980.0000 =	...
COMP.NO. 199 = + 1990.0000 =	...
#	Final character (#)



ND 287 with rotary encoder connected to input X1

The compensation points have a fixed spacing of two degrees relative to each other.

Parameter		Meaning	
#		Start character (#)	
ND-287 1	DEG	Model: ND-287, Unit of measure: DEG, DMS or rad	
AXIS X1	= 0	Axis to be compensated	
COMP.NO. 000	= + 0.0000 = +0.0000	Compensation value 0 = 0.0000 mm (Compensation value 0 is always 0.0000 mm.)	
COMP.NO. 001	= + 2.0000 = ...	Compensation value 1 = No value entered	
COMP.NO. 002	= + 4.0000 = ...	Compensation values 2 - 179 = No values entered Axis will not be compensated.	
COMP.NO. 003	= + 6.0000 = ...		
COMP.NO. 004	= + 8.0000 = ...		
COMP.NO. 005	= + 10.0000 = ...		
COMP.NO. 006	= + 12.0000 = ...		
COMP.NO. 007	= + 14.0000 = ...		
COMP.NO. 008	= + 16.0000 = ...		
COMP.NO. 009	= + 18.0000 = ...		
COMP.NO. 010	= + 20.0000 = ...		
COMP.NO. 011	= + 22.0000 = ...		
COMP.NO. 012	= + 24.0000 = ...		
COMP.NO. 013	= + 26.0000 = ...		
COMP.NO. 014	= + 28.0000 = ...		
COMP.NO. 015	= + 30.0000 = ...		
COMP.NO. 016	= + 32.0000 = ...		
COMP.NO. 017	= + 34.0000 = ...		
COMP.NO. 018	= + 36.0000 = ...		
...			
COMP.NO. 173	= + 346.0000 = ...		
COMP.NO. 174	= + 348.0000 = ...		
COMP.NO. 175	= + 350.0000 = ...		



II – 7 Input and Output of Parameter List and Error Compensation Table

Parameter	Meaning
COMP.NO. 176 = + 352.0000 = ...	
COMP.NO. 177 = + 354.0000 = ...	
COMP.NO. 178 = + 356.0000 = ...	
COMP.NO. 179 = + 358.0000 = ...	
#	Final character (#)



II – 8 Specifications

ND 287

Specifications	
Axes	Up to two axes. The second axis is optional.
Encoder input	<ul style="list-style-type: none"> ■ Incremental HEIDENHAIN encoders <ul style="list-style-type: none"> ■ Sinusoidal signals 11 μA_{PP}, input frequency max. 100 kHz ■ Sinusoidal signals 11 V_{PP}, input frequency max. 500 kHz ■ Absolute HEIDENHAIN encoders with EnDat 2.1/2.2 interface <p>Possible signal periods for linear and rotary encoders:</p> <ul style="list-style-type: none"> ■ For rotary encoders: 1 - 999 999.999 ■ For linear encoders: 0.000 000 01 μm - 99 999.9999 μm
Display step	<ul style="list-style-type: none"> ■ Linear axes: 0.5 mm to 0.001 μm, depending on the signal period ■ Rotary axes: 0.5° to 0.000001° (00°00'00.1"), depending on the signal period
Display	<p>Color LCD display for position values, dialog and input display, graphic functions, graphic positioning aid</p> <ul style="list-style-type: none"> ■ Status display: Operating mode, axis/coupled axes, scale factor, compensation, stopwatch, unit of measure, datum number, soft-key row ■ Position display and measured-value display with selectable display resolution
Conversational language	English, German, French, Japanese, Chinese (simplified)



Specifications

Functions

- Multilingual user guidance
- REF reference-mark evaluation for distance-coded or single reference marks
- Display for lengths, angles, or optionally for other measured values from analog sensors
- Distance-To-Go or Actual Value operating mode
- Two datums
- Scaling factor
- Stopwatch
- Reset or Preset function, also through external signal
- Linear or non-linear error compensation for **axis-error compensation**
- Trigger signals
- Series of measurements:
 - **Sorting** measured values and finding the **Minimum, Maximum, Sum, Difference** or a definable **coupled position value**. Displaying the sorting results in order to intervene, if necessary.
 - Memory capacity for series of measurements: **Up to 10 000 measured values per axis.**
 - Analysis of series of measurements: **Arithmetical mean value, standard deviation, graphical representation** of all measured values with minimum, maximum and mean value of the series of measurements.
 - Measured-value acquisition by **external signal** or **selectable sampling interval**, or by pressing the ENTER key.
- **Statistical Process Control (SPC):**
 - Calculation of **arithmetical mean value, standard deviation** and **range**. Displaying **graphs** or histograms with **symmetrical or asymmetrical density function**.
 - **Process capability indices c_p and c_{pk} , quality control charts** for mean value, standard deviation and range.
 - Measured-value acquisition by **external signal** or by pressing the ENTER key.
 - FIFO memory capacity: **Up to 1000 measured values.**
- **Diagnostics function** for testing the encoder, the keyboard, the screen, the supply voltage and the switching inputs/outputs
- **Data transfer** of measured values and compensation values, configuration parameters or software downloads via a serial interface
- **Integrated help system**

Error compensation

- Linear axes: Linear and non-linear (up to 200 compensation points)
- Rotary axes: Non-linear (180 fixed compensation points spaced at 2°)
- Axis-error compensation with temperature sensor
- Temperature compensation using a reference part



Specifications	
Data interface	<p>Two serial interfaces:</p> <ul style="list-style-type: none"> ■ RS-232-C/V.24 110 to 115 200 baud ■ USB Type B (UART) <p>You can use only one interface for data transfer at a time. The data transfer software TNCremoNT is available for free on the HEIDENHAIN web site at www.heidenhain.de on the downloads page under Services and Documentation.</p>
Optional accessories	<ul style="list-style-type: none"> ■ Encoder module for connecting a HEIDENHAIN encoder with 11-μApp, 1-Vpp or EnDat 2.1/2.2 interface for a second axis X2 ■ Analog module as input assembly X1 and/or X2 for connecting an analog sensor with ±10 V interface, 24 V supply voltage, preferably a temperature sensor for axis-error compensation ■ Ethernet module (100baseT) for network connection via TCP/IP protocol ■ Mounting base for installation in a 19-inch electrical cabinet ■ Adapter cables with D-sub connector for HEIDENHAIN encoders ■ Length gauge with D-sub connector ■ Data transmission cable for RS-232-C/V.24 interface ■ Data transmission cable for USB interface
Main power input	100 V~ to 240 V~; 50 Hz to 60 Hz
Line fuse	2 x T500 mA
Power	Max. 30 VA
Electromagnetic compatibility/ CE compliance	<p>The encoder fulfills the requirements for electromagnetic compatibility according to 2004/108/EEC with respect to the generic standards for</p> <ul style="list-style-type: none"> ■ Noise immunity (IEC 61000-6-2) ■ Emission (IEC 61000-6-4)
Operating temperature	0 °C to 50 °C (32 °F to 122 °F)
Storage temperature	-40 °C to 85 °C (-40 °F to 185 °F)
Relative air humidity	<p>Annual mean: < 75%</p> <p>In exceptional cases: < 90%</p>
Protection (IEC 60529)	IP 40 rear panel, IP 54 front panel
Weight	Approx. 2.5 kg (5.5 lb.)
Housing	Benchtop design, cast-metal housing
Housing dimensions	Width: 211 mm, height: 112 mm (including feet), depth: 251 mm (including connector)



II – 9 Dimensions

ND 287

Dimensions in mm

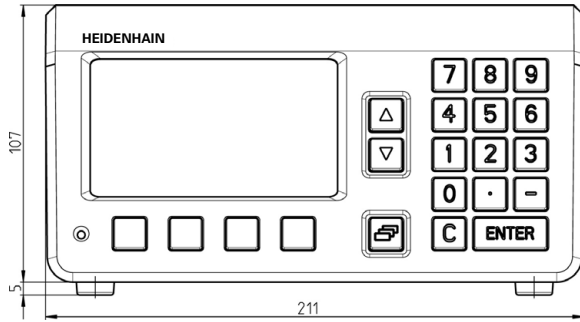

Front view with dimensions

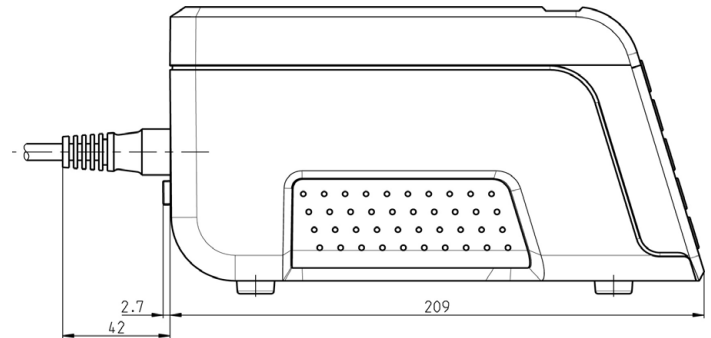

Side view with dimensions

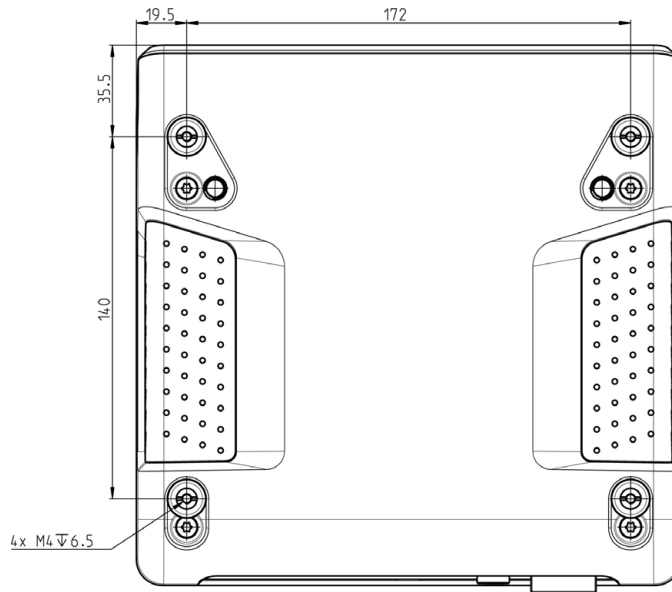

Bottom view with dimensions

Dimensions in mm



Tolerancing ISO 8015
ISO 2768 - m H
< 6 mm: ± 0.2 mm



II – 10 Accessories

ID numbers for accessories

ID number	Accessories
654017-01	Encoder module, packaged
654018-01	Analog module, packaged
654019-01	Ethernet module, packaged
654020-01	Mounting base for installation in a 19-inch electrical cabinet, packaged
366964-xx	Data transfer cable for RS-232-C/V.24 interface, packaged
354770-xx	Data transfer cable for USB interface, packaged



Mounting the input assemblies



Danger to the operator and internal components!

- Do not mount the input assembly while the unit is under power!
- Disengage the power plug before opening the unit!

An encoder module for connecting a HEIDENHAIN encoder with 11 μ App, 1 Vpp or EnDat 2.1/2.2 interface for axis X1 is a standard item supplied with the position display unit. As an option, you can replace this module by an analog module. If you want to install another encoder module or analog module, you can connect it to input X2. Use input X26(X27) to install an Ethernet module.

Mounting or exchanging the modular input assembly:

- ▶ Switch the ND 287 position display unit off and disengage the power plug.
- ▶ Loosen the Torx screws securing the cover of the selected input.
- ▶ Remove the cover, or pull out the module if a module is connected.
- ▶ Insert the new input assembly and re-tighten the Torx screws.

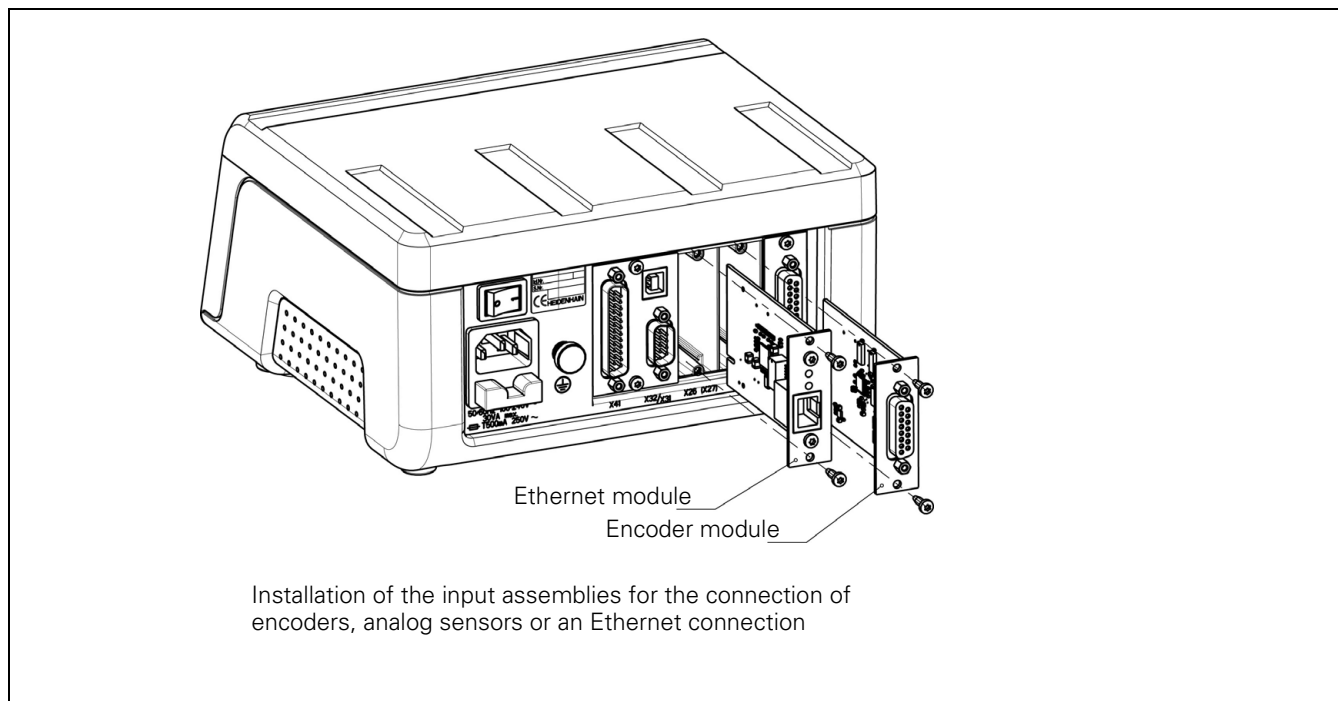

Mounting base for installation in 19-inch electrical cabinet

ID number 654020-01

Dimensions (mm)

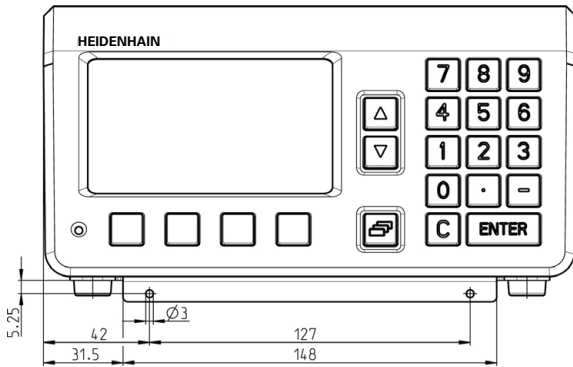

Front view with dimensions

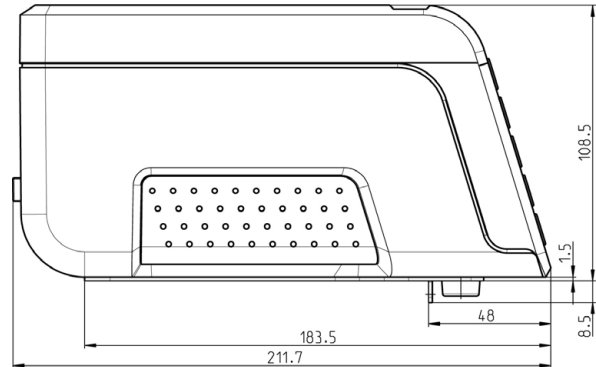

Side view with dimensions

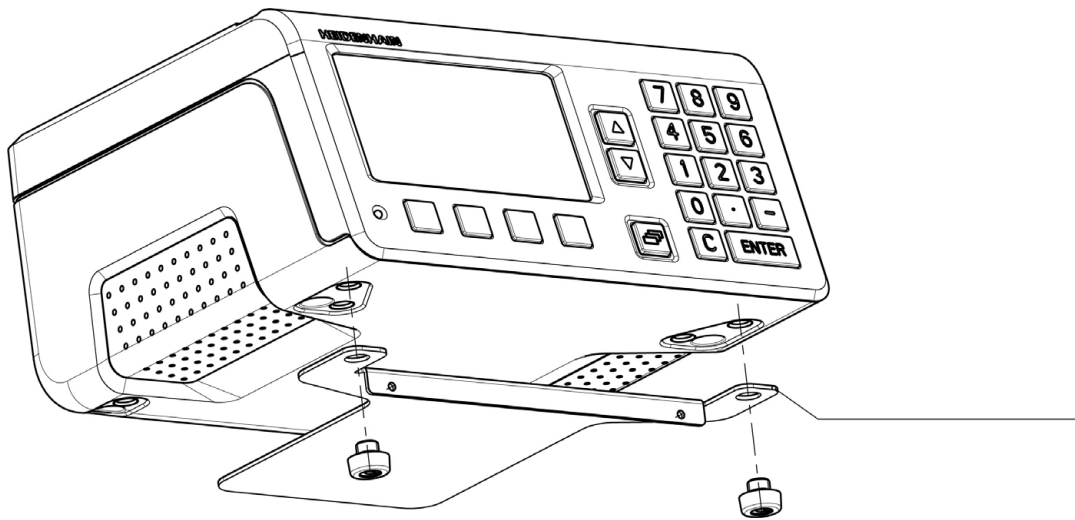

Dimensions in mm



Tolerancing ISO 8015
ISO 2768 - m H
< 6 mm: ± 0.2 mm

3-D view, secure the mounting base with two M4 x 6 screws to the electrical cabinet.





- A**
 Absolute coordinates ... 18
 Absolute datum ... 16
 Absolute position encoders ... 19
 Absolute workpiece positions ... 18
 Accessories ... 64, 139
 Actual position ... 17
 Actual Value/Distance-To-Go soft key ... 30
 Analog sensor ... 76
 Angle encoders from HEIDENHAIN ... 100
- B**
 Basic functions ... 21
- C**
 C key ... 27
 CE compliance ... 66
 Compensation using a reference part ... 41
 Console adjustment ... 37
 Control limits ... 54
 Counter settings ... 78
 Coupled position, definition of formula ... 79
- D**
 Data input ... 27
 Data input forms ... 29
 Data interface ... 101
 Data transfer
 Control characters ... 103
 Data format ... 103
 from PC ... 103
 Signal level ... 105
 to a printer ... 102
 to PC ... 102
 Datum setting ... 31, 36
 Datums ... 16
 Diagnostics ... 88
 Display test ... 88
 Encoder test ... 89
 Keypad test ... 88
 Power supply ... 91
 Switching inputs test ... 92
 Switching outputs test ... 93
 Dimensions ... 138
 Display configuration ... 77
 Display mode ... 27
 Display value, setting ... 31, 32
 Distance-coded reference marks ... 20
 Distance-to-go ... 17
- E**
 Electrical connection ... 67
 Electrical requirements ... 67
 Electromagnetic compatibility (EMC) ... 66
 Encoder parameters ... 99
 Encoder setup ... 72
 Absolute encoder ... 75
 Analog sensor ... 76
 Incremental angle encoder ... 74
 Incremental linear encoder ... 73
 Encoders, connecting the ... 68
 Environmental conditions ... 65
 Error compensation ... 80
 Error compensation table, creating... ... 83
 Linear ... 81
 Non-linear ... 82
 Error compensation table ... 83
 Configuring ... 84
 Examples ... 129
 Export ... 85
 Graph, viewing... ... 84
 Import ... 85
 Output format ... 126
 Viewing ... 84
 Error messages ... 29, 60
 External operation ... 107
- F**
 Factory defaults ... 78
 Firmware update ... 104
 Fixed reference marks ... 20
 Function of external inputs ... 40
 Fundamentals of positioning ... 16
- G**
 Grounding ... 67
- H**
 Help system ... 28
- I**
 Incremental coordinates ... 18
 Incremental position encoders ... 19
 Incremental workpiece positions ... 18
 Input signals ... 95
 Installation setup ... 70
 INSTALLATION SETUP menu ... 70
 Instruction box ... 29
 Instruction messages ... 29
 Integrated help system ... 28
 Interface, setting up... ... 86
 Items supplied ... 64
- J**
 Job setup ... 30
 JOB SETUP menu ... 33
 Job Setup menu ... 33, 71
- K**
 Key 'ENTER' ... 27
 Keypad, using the... ... 27
- L**
 Language (setting) ... 37
 Linear encoders from HEIDENHAIN ... 99
- M**
 Maintenance ... 68
 Measured value output ... 39, 114
 after trigger signal ... 114
 via data interface ... 115
 Measured values, recording... ... 47
 Mirror ... 35
 Mode of recording ... 47
 Mounting ... 65
 Input assemblies ... 140
 Mounting and installation ... 65
 Mounting base ... 141
 Mounting location ... 65
- N**
 ND, power up ... 21
 ND, switch-off ... 22
 NO REF soft key ... 22
 Nominal position ... 17
 Non-linear error compensation ... 82
- O**
 Operating modes ... 30
 Optional accessories ... 64
 Output signals ... 96

- P**
- Parameter list
 - Example ... 119
 - Input and output ... 117
 - Output format ... 118
 - Passcode ... 70
 - Position encoders ... 19
 - Position feedback ... 19
 - Possible applications ... 14
 - Power connector ... 67
 - Power up ... 21
 - Preventative maintenance ... 68
- R**
- Recording ... 47
 - REF ... 19
 - Reference mark evaluation ... 22
 - Reference mark signals, ignoring ... 95
 - Reference marks ... 20
 - crossing over ... 22
 - Not crossing over ... 22
 - Reference part ... 41
 - Repair ... 68
 - RS-232-C/V.24 interface ... 86, 101
- S**
- Samples ... 52
 - Scaling factor ... 35
 - Screen layout ... 23
 - Serial data transfer ... 102
 - Serial port ... 86
 - Series of measurements ... 42
 - Analysis ... 43
 - Calling the menu ... 43
 - Defining the display ... 46
 - Functions ... 42
 - Setting up ... 44
 - Starting and stopping ... 48
 - Switching between series of measurements and SPC mode ... 42
 - Signal level ... 95
 - Soft key LIST OF TOPICS ... 28
 - Soft key mm/inch ... 34
 - Soft-key functions ... 25
 - Software update (firmware update) ... 104
 - Sorting and tolerance checking ... 58
 - Defining the parameters ... 59
 - Status display ... 58
 - Sorting limits ... 98
 - Specifications ... 135
 - Stacking ... 65
 - Standard screen ... 23
 - Statistical process control ... 42
 - Analysis ... 49
 - Control limits ... 54
 - Delete statistic ... 56
 - Measured value recording ... 55
 - Menu, calling the ... 49
 - Samples ... 52
 - Setting up ... 52
 - Starting and stopping ... 56
 - Statistical distribution ... 55
 - tolerances ... 53
 - Stopwatch (setting) ... 36
 - Switching inputs ... 94
 - Switching outputs ... 96
 - Switching signals ... 38
- T**
- Tolerance limits ... 53
 - Trigger limits ... 97
- U**
- Unit of measure, setting ... 34
 - Up/Down arrow keys ... 27
 - Update ... 104
 - USB interface ... 86, 101, 106
- V**
- Value for datum point ... 36
- W**
- Wiring the connecting cable ... 105
 - RS-232-C/V.24 ... 105
 - USB ... 106
- Z**
- Zero crossover ... 98



HEIDENHAIN

DR. JOHANNES HEIDENHAIN GmbH

Dr.-Johannes-Heidenhain-Straße 5

83301 Traunreut, Germany

☎ +49 (8669) 31-0

FAX +49 (8669) 5061

E-Mail: info@heidenhain.de

Technical support FAX +49 (8669) 32-1000

Measuring systems ☎ +49 (8669) 31-3104

E-Mail: service.ms-support@heidenhain.de

TNC support ☎ +49 (8669) 31-3101

E-Mail: service.nc-support@heidenhain.de

NC programming ☎ +49 (8669) 31-3103

E-Mail: service.nc-pgm@heidenhain.de

PLC programming ☎ +49 (8669) 31-3102

E-Mail: service.plc@heidenhain.de

Lathe controls ☎ +49 (8669) 31-3105

E-Mail: service.lathe-support@heidenhain.de

www.heidenhain.de